

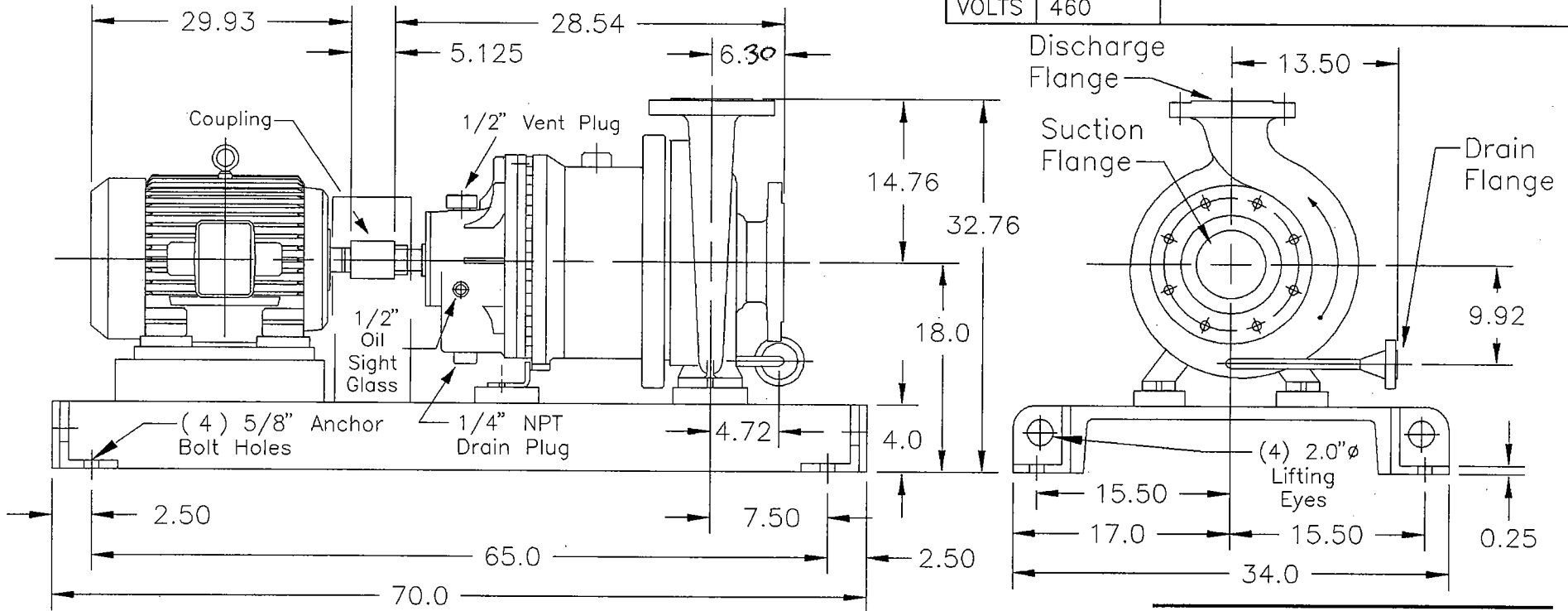

SERIAL NUMBER(S):
P00060312

PUMP DATA:		MOTOR DATA:		NOTES:
MODEL	SLM-NVO-200-150-250-16E06	MFG	TECO-	COUPLING: REXNORD OMEGA ES20
SIZE	8 X 6 X 10		WESTINGHOUSE	
SUCT. FLG.	8.0", 150# RF	HP	40	PT-100 TEMPERATURE PROBE
DISCH. FLG.	6.0", 150# RF	RPM	1800	PMP-25 POWER MONITOR
DRAIN CONN.	1/2", 150# RF	ENCL	TEFC	DOUBLE ISOLATION SHELL
		FRAME	324T	EQUIPPED WITH CDS SYSTEM
		PH/HZ	3/60	
		VOLTS	460	



ALL DIMENSIONS ± 1/8" UNLESS OTHERWISE NOTED.

CERTIFIED CORRECT:
DATE: 20-MAR-2006
BY: JOHN BUTLER

REV.	DATE	COMMENTS
1	5-11-06	PUMP CENTER LINE CHANGE

PUMP UNIT DRAWING

CUSTOMER	DECUSSA CORPORATION
ENG. CONTR.	
PROJECT NO.	C0150.10002
P.O. NO.	4500164995
ITEM NO.	3021.00
KU JOB NO.	06-007
EST. WEIGHT	2270 lbs
DWG.CODE NO:	
DRAWING NO.	06-007-3021.Dwg
DATE	03-APR-2006