



PROVNINGSPROTOKOLL / DELIVERY TEST REPORT

SERIENUMMER	SERIAL NUMBER	AAF0000760
DATUM	DATE	2022-10-07
SIGN.	SIGN.	SEESBLG
MASKINTYP	MACHINE TYPE	BRPX 714HGV-34C
SPEC.PROD.NR.	SPEC.PROD.NO.	8812080304
KONFIGURATION.NR.	CONFIGURATION NO.	N/A
TILLVERKNING.NR.	MANUFACT.NO.	1100021522
FÖRS.ORDER.NR.	SALES ORDER NO.	26359
SK. DOK. NR.	SK. DOC. NO.	N/A
PF NUMMER	PF NUMBER	9036890
UTGÅVA	EDITION	0
BATCH ID	BATCH ID	11862
PROVAD DEN	TEST DATE	2022-10-25 15:07
PROVAD AV	TESTED BY	PAG
PROVNINGSRIGG	TESTING DEVICE	Rigg A

SPECIFIKATION	SPECIFICATION	LIMITS	RESULTS
Angiven effekt	Rated power	N/A kW	OK
Angiven ström	Rated current	N/A A	OK
Angiven spänning	Rated voltage	N/A V	OK
Nätfrekvens	Frequency	N/A Hz	OK
Utväxling	Gear ratio	91:32	OK
Normal starttid	Standard start up time	1020 sec	OK
Max. vibration extern	Max vibration extern	7,1 mm/s	2,7 mm/s
Max. vibration YT750	Max vibration YT750	7,1 mm/s	1,9 mm/s
Max. vibration YT751	Max vibration YT751	N/A mm/s	N/A mm/s
Kulans maxvarvtal	Max bowl speed	5119 RPM	5073 RPM
Motorns maxvarvtal	Max motor speed	1800 RPM	1784 RPM
Flöde inlopp	Inlet flow	19-21 m³/h	20,0 m³/h
Tryck inlopp	Inlet pressure	N/A kPa	N/A kPa
Flöde lättfas	Light phase flow	N/A m³/h	N/A m³/h
Tryck lättfas	Light phase pressure	N/A kPa	N/A kPa
Flöde tungfas	Heavy phase flow	N/A m³/h	N/A m³/h
Tryck tungfas	Heavy phase pressure	N/A kPa	N/A kPa
Normal stopptid	Standard stop time	2700 sec	OK sec
Lufttryck OWM	Air pressure OWM	400 kPa	OK kPa
Skottvol. normal skott	Discharge vol. standard	6-9 l	8 l
Skottvol. stort skott	Discharge vol. large	14-17 l	15 l

Anteckningar/Notes

Godkänd av/Approved by	Datum/Date
	20221027





MATERIALIDENTIFIKATIONSNUMMER
MATERIAL IDENTIFICATION NUMBER

Maskintyp/Machine type BRPX 714HGV-34C		Serienummer/Serial Number AAF0000760	
PF Nr/PF No 9036890	Utgåva/Edition 0	Datum/Date 2022-10-25 12:56	Sign PAG

Separatordelar Parts of separator	Nummer enligt AL 100 1550 Number according to AL 100 1550
Kulkropp Bowl body	BPL 69222
Kulhuv Bowl hood	BPL 68456
Låsring stora Lock ring large	BWK 1301
Låsring lilla Lock ring small	N/A
Slidallrik Sliding bowl bottom	BPL 68689
Fjäderhållare Spring support	BWK 1034
Doseringsring Dosing ring	N/A
Ventilslid Valve slide	N/A
Fördelare Distributor	L 265
Fördelningskona Distributing cone	L 274
Manöverslid Operating slide	BPL 61647
MotorID Motor ID	LÅNE MOTOR

Maskintyp/Machine type BRPX 714HGV-34C		Serienummer/Serial Number AAF0000760	
PF Nr/PF No 9036890	Utgåva/Edition 0	Datum/Date 2022-10-25 12:56	Sign PAG
Vibrationsmätning enligt 547168 Vibration measurement acc. to E 547168		Mätutrustning/Metod Measuring equipment/Method ISO 2954/ISO 2372	

VIBRATION MEASUREMENT REPORT

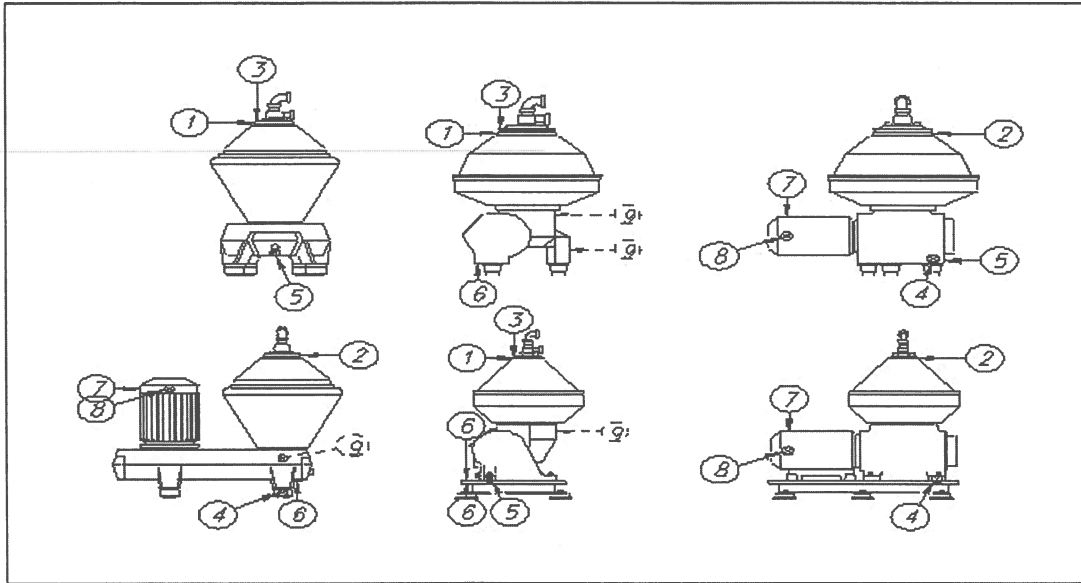

Operating conditions

Flow	20 m ³ /h	Counter pressure	280,9 kPa
------	----------------------	------------------	-----------

External sensors

Max vibration SP	7,1										
Test points	1	2	3	4	5	6	7	8	9	10	
Sensor name	VT01	VT02	VT03	VT04	VT05	VT06	VT07	VT08	VT09	VT10	
Max value	2,2	2	0,4	2,7	2,4	1,4	1,4	1,7	1,7	N/A	mm/s

Internal sensors

Max vibration setpoint	7,1	N/A	
Sensor name	YT750	YT751	
Max value	1,9	N/A	mm/s

Remarks



This page is intentionally left blank

