

NOTES:



APPROVED BY: _____
 DRAWN BY: JWF
 CHECKED BY: JMZ
 DATE: 5-26-2016

THE INFORMATION CONTAINED IN THIS DRAWING IS THE SOLE PROPERTY OF BMT USA, LLC. ANY REPRODUCTION IN PART OR AS A WHOLE WITHOUT THE WRITTEN PERMISSION OF BMT USA, LLC. IS STRICTLY PROHIBITED.

UNLESS OTHERWISE SPECIFIED:
 DIMENSIONS ARE IN INCHES
 TOLERANCES:
 FRACTIONAL ±1/8
 ANGULAR: BEND ±1°
 TWO PLACE DECIMAL ±.06
 THREE PLACE DECIMAL ±.030

GENERAL ARRANGEMENT VIEWS: ECSG 400

CUST.		BMT USA, LLC 14532 169th Dr. SE, Suite 142 Monroe, WA 98272		TEL. 360-863-2252 FAX 360-863-2366 www.bmtus.com	
Golden Road Brewing		MODEL #	ECSG400	SERIAL #	SG1641003
DESC.	Electric Clean Steam Generator 400 lbs./hr	DWG. #	SG1641003-GA1	REV	A
SCALE:		WEIGHT:		SHEET 1 OF 4	

Utility ID Tag	Utility/ Connection Type	Size & Type	Material	Capacity Requirement	Pressure Requirement
CS	Clean steam (dry, saturated)	2" Tri-clamp	316 SS	400 lbs./hr. (output)	45 psig
DR	Waste drain	1" npt	304SS	8 gpm max. @ < 140 F	To open sink
E1'	Electrical supply ECSCG	Conduit	by installer	180FLA	480V/3PH/60HZ
E2'	Electrical supply RO System	Conduit	by installer	11 FLA	110V/1PH/60HZ
VT1	Safety relief valve - Clean steam	1" npt	Brass		
IW	Soft Dechlorinated water	1" npt	316SS	2 gpm min 6 gpm max	40-60 psig
IA	Compressed Air	3/8" npt	304SS	3 scfm avg.	80-100 psig

¹ Knock outs for E1 & E2 plus all required conduit and fittings are provide at site by installer. Proper care must be taken to prevent metal debris fomr entering electrical enclosures when making penetrations. Component failure caused be debris of this nature is not covered by warranty.

NOTES / GENERAL INSTALLATION REQUIREMENTS	
1	Heat emission @ 70 F: 1200 BTU/hr.
2	Estimated operating weight: 800 lbs.
3	Diameter of all piping connections to/from steam generator should be equal to connection points - no reductions.
4	Shut off valves for maintenance are required and must be installed to be accessible (by others, at site)
5	Service area / mechanical space must be provided with adequate lighting.
6	Per N.E.C. provide 42" free space, 36" wide in front of 480Vpanel.

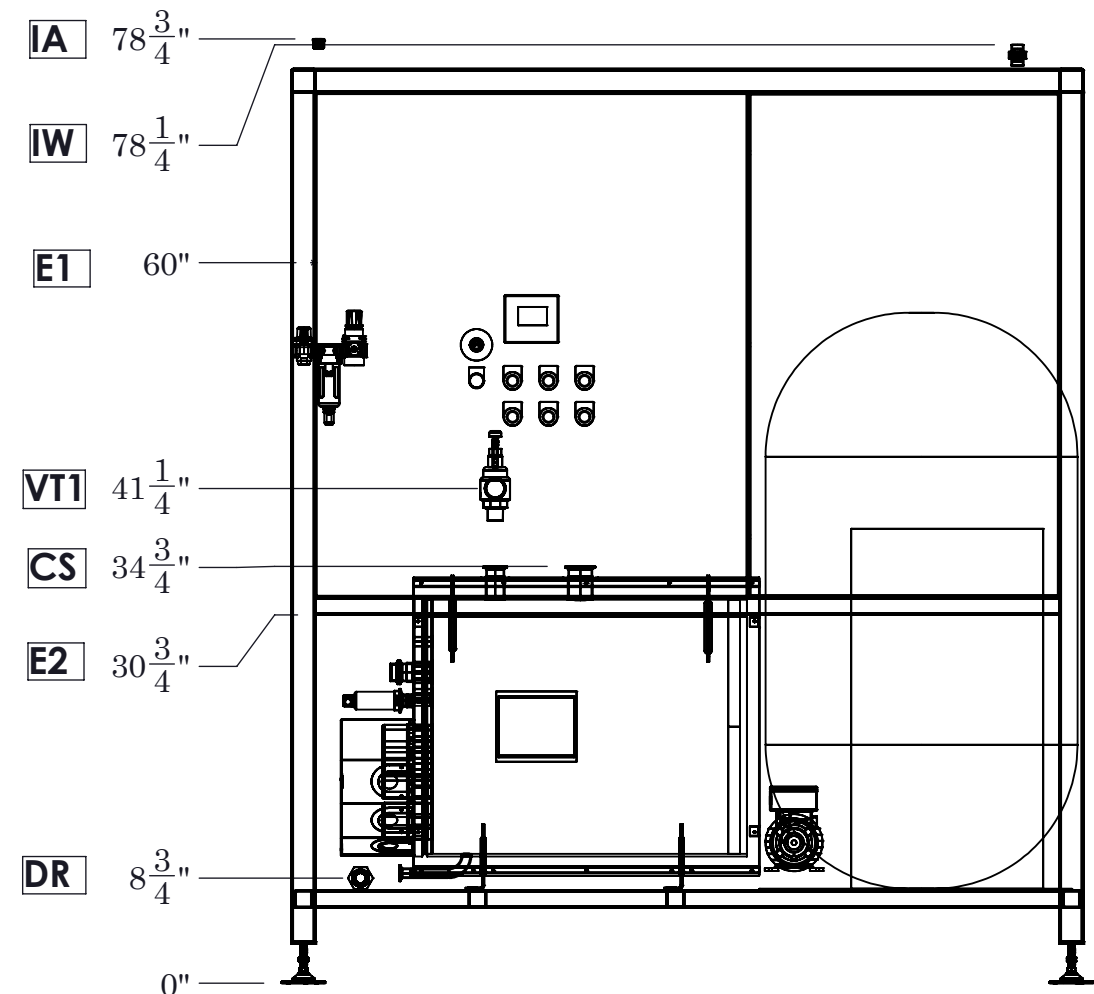
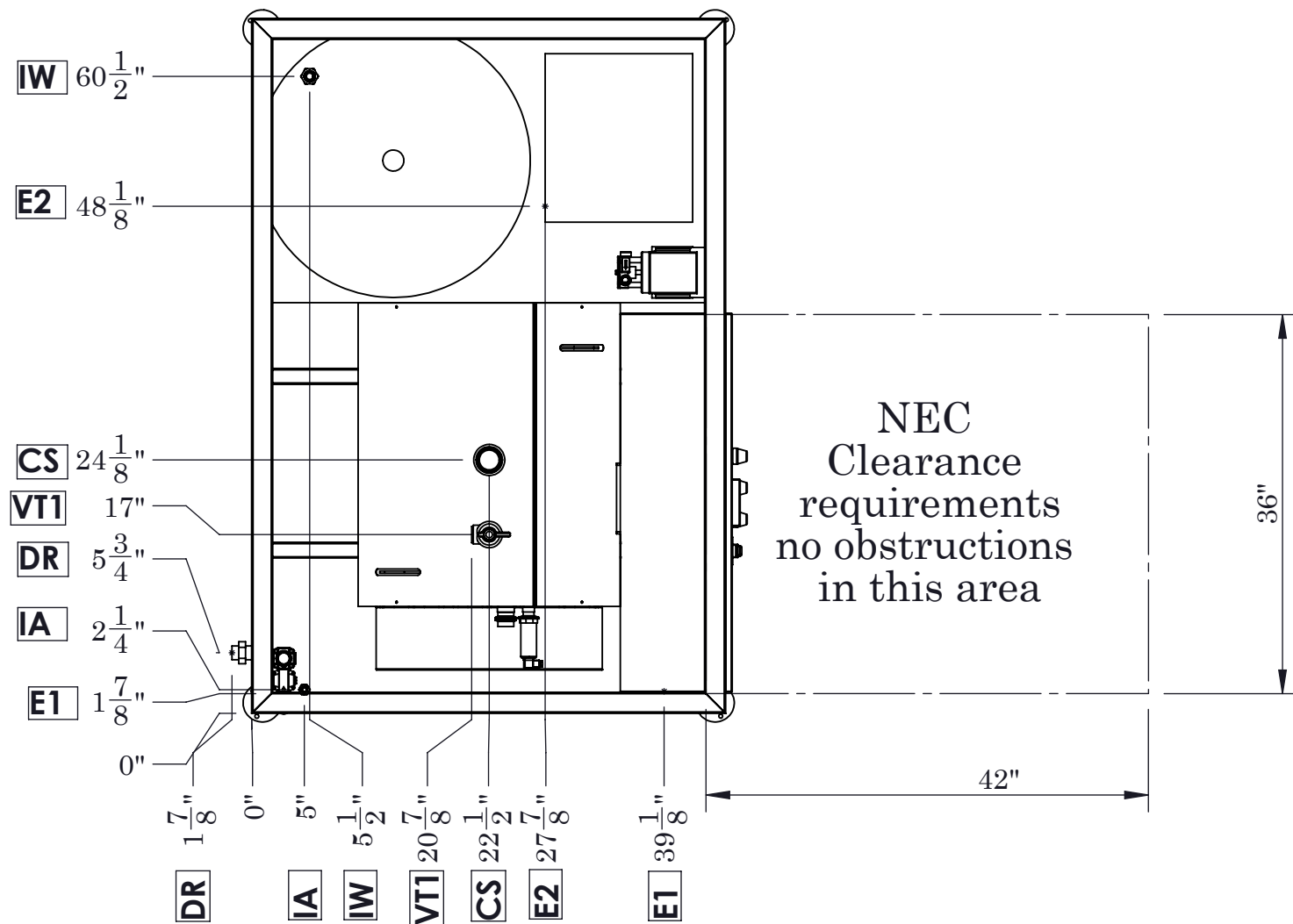

NOTES:



APPROVED BY: _____
 DRAWN BY: JWF
 CHECKED BY: JMZ
 DATE: 5-26-2016

THE INFORMATION CONTAINED IN THIS DRAWING IS THE SOLE PROPERTY OF BMT USA, LLC. ANY REPRODUCTION IN PART OR AS A WHOLE WITHOUT THE WRITTEN PERMISSION OF BMT USA, LLC. IS STRICTLY PROHIBITED.

UNLESS OTHERWISE SPECIFIED: CUST.
 DIMENSIONS ARE IN INCHES
 TOLERANCES:
 FRACTIONAL ±1/8
 ANGULAR: BEND ±1°
 TWO PLACE DECIMAL ±.06
 THREE PLACE DECIMAL ±.030

GENERAL ARRANGEMENT - UTILITY SUPPLIES			
Golden Road Brewing		BMT USA, LLC 14532 169th Dr. SE, Suite 142 Monroe, WA 98272	
DESC. Electric Clean Steam Generator 400 lbs./hr.		MODEL # ECSCG400	SERIAL # SG1641003
B	DWG. # SG1641003-GA2	REV A	
SCALE:	WEIGHT:	SHEET 2 OF 4	

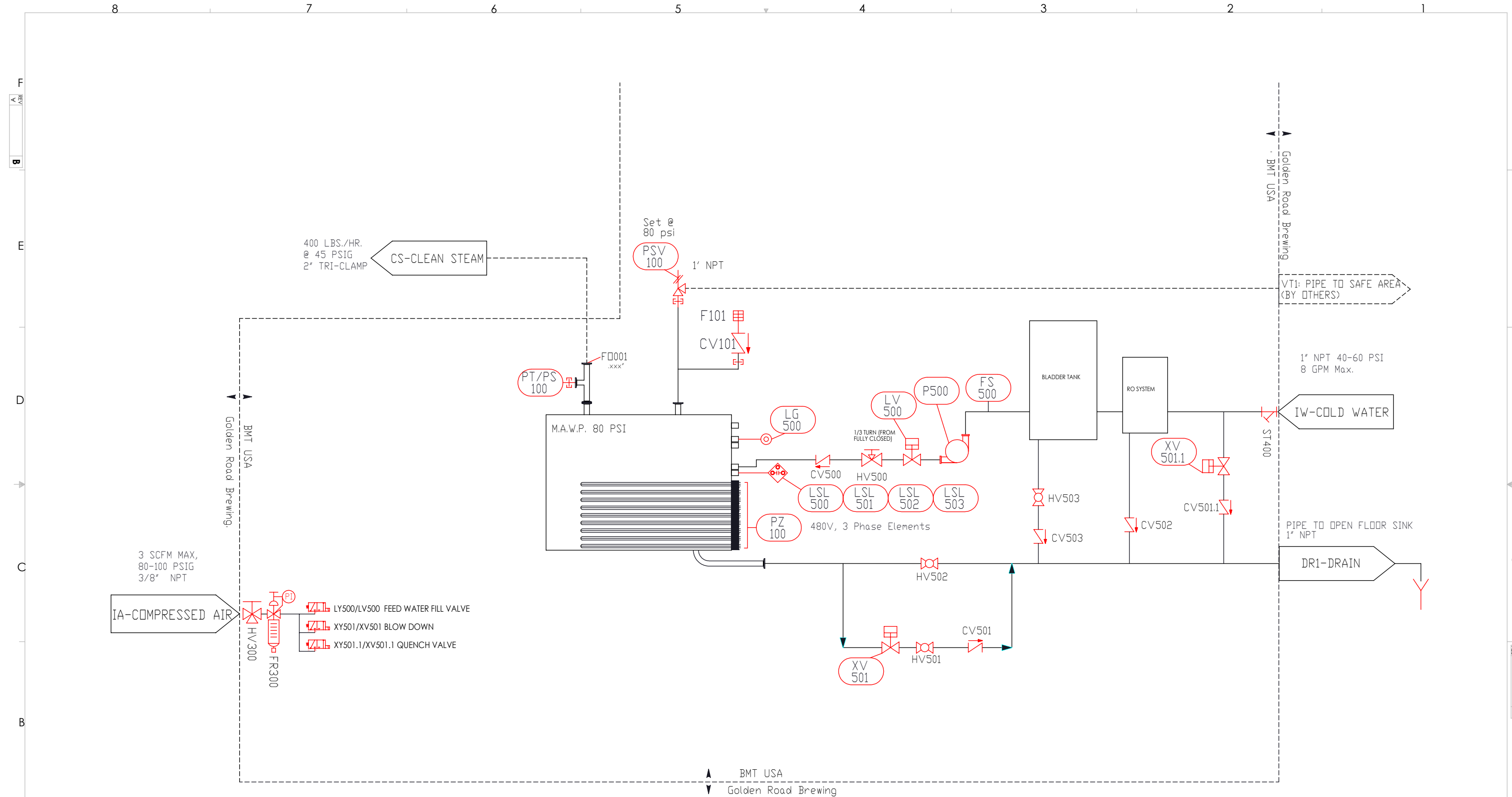

PROCESS AND INSTRUMENTATION DIAGRAM: ECSG400



APPROVED BY: _____
 DRAWN BY: JWF
 CHECKED BY: JMZ
 DATE: 5-26-2016

THE INFORMATION CONTAINED IN THIS DRAWING IS THE SOLE PROPERTY OF BMT USA, LLC. ANY REPRODUCTION IN PART OR AS A WHOLE WITHOUT THE WRITTEN PERMISSION OF BMT USA, LLC. IS STRICTLY PROHIBITED.

UNLESS OTHERWISE SPECIFIED:
 DIMENSIONS ARE IN INCHES
 TOLERANCES:
 FRACTIONAL ±1/8
 ANGULAR: BEND ±1°
 TWO PLACE DECIMAL ±.03
 THREE PLACE DECIMAL ±.01

CUST. **Golden Road Brewing**
 DESC. **Electric Clean Steam Generator 400lbs./hr**

BMT USA, LLC 14532 169th Dr. SE, Suite 142 Monroe, WA 98272 TEL: 360-863-2252 FAX: 360-863-2366 www.bmtus.com	
MODEL #	ECSG400 SERIAL # SG1641003
DWG. #	B SG1641003-PID REV A
SCALE:	WEIGHT: SHEET 3 OF 4

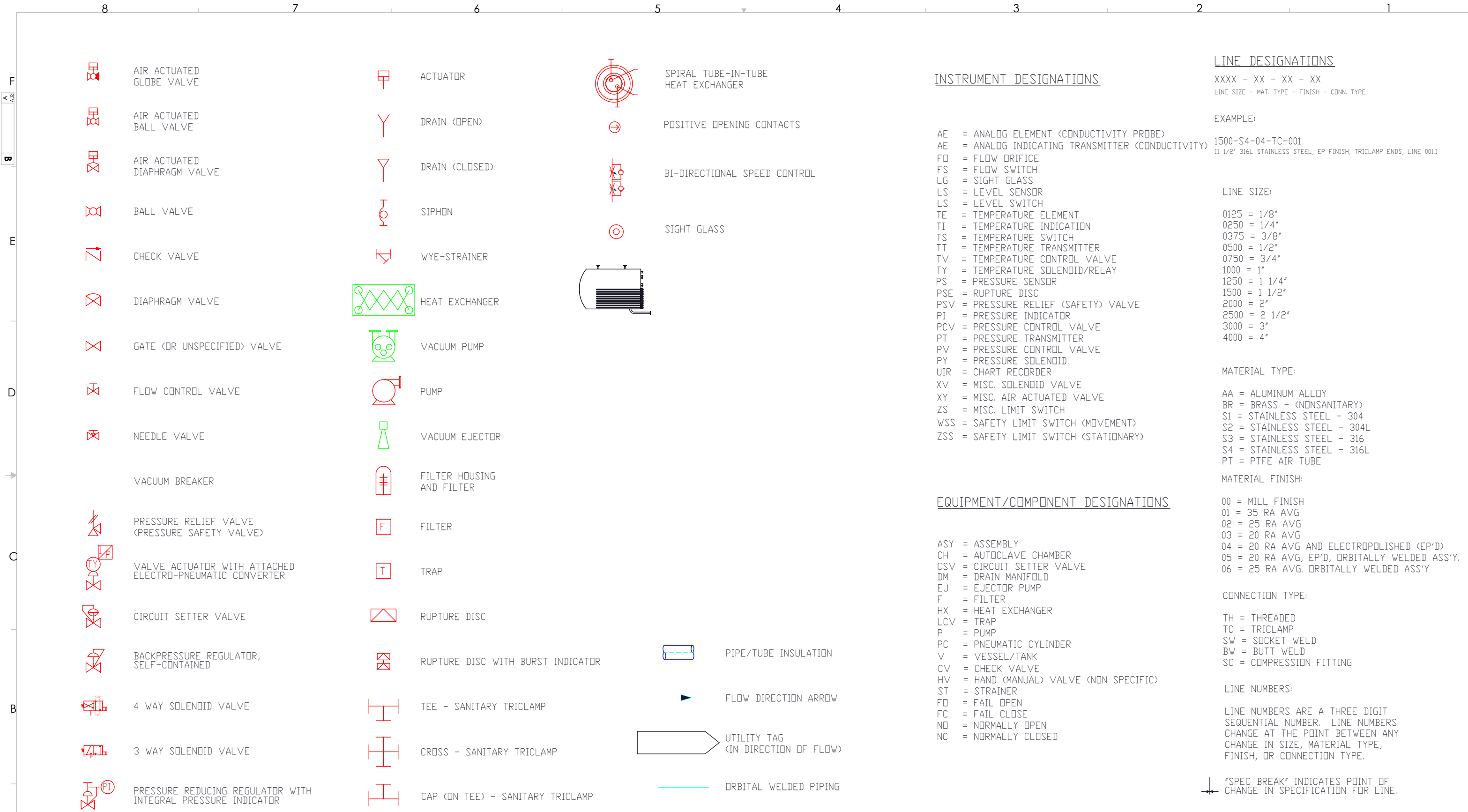

INSTRUMENT DESIGNATIONS

- AE = ANALOG ELEMENT (CONDUCTIVITY PROBE)
- AE = ANALOG INDICATING TRANSMITTER (CONDUCTIVITY)
- FO = FLOW ORIFICE
- FS = FLOW SWITCH
- LG = SIGHT GLASS
- LS = LEVEL SENSOR
- LS = LEVEL SWITCH
- TE = TEMPERATURE ELEMENT
- TI = TEMPERATURE INDICATION
- TS = TEMPERATURE SWITCH
- TT = TEMPERATURE TRANSMITTER
- TV = TEMPERATURE CONTROL VALVE
- TY = TEMPERATURE SOLENOID/RELAY
- PS = PRESSURE SENSOR
- PSE = RUPTURE DISC
- PSV = PRESSURE RELIEF (SAFETY) VALVE
- PI = PRESSURE INDICATOR
- PCV = PRESSURE CONTROL VALVE
- PT = PRESSURE TRANSMITTER
- PV = PRESSURE CONTROL VALVE
- PY = PRESSURE SOLENOID
- UIR = CHART RECORDER
- XV = MISC. SOLENOID VALVE
- XY = MISC. AIR ACTUATED VALVE
- ZS = MISC. LIMIT SWITCH
- WSS = SAFETY LIMIT SWITCH (MOVEMENT)
- ZSS = SAFETY LIMIT SWITCH (STATIONARY)

LINE DESIGNATIONS

XXXX - XX - XX - XX
 LINE SIZE - MAT. TYPE - FINISH - CONN. TYPE

EXAMPLE:
 1500-S4-04-TC-001
 (1 1/2" 316L STAINLESS STEEL, EP FINISH, TRICLAMP ENDS, LINE 001.)

LINE SIZE:

- 0125 = 1/8"
- 0250 = 1/4"
- 0375 = 3/8"
- 0500 = 1/2"
- 0750 = 3/4"
- 1000 = 1"
- 1250 = 1 1/4"
- 1500 = 1 1/2"
- 2000 = 2"
- 2500 = 2 1/2"
- 3000 = 3"
- 4000 = 4"

MATERIAL TYPE:

- AA = ALUMINUM ALLOY
- BR = BRASS - (NONSANITARY)
- S1 = STAINLESS STEEL - 304
- S2 = STAINLESS STEEL - 304L
- S3 = STAINLESS STEEL - 316
- S4 = STAINLESS STEEL - 316L
- PT = PTFE AIR TUBE

MATERIAL FINISH:

- 00 = MILL FINISH
- 01 = 35 RA AVG
- 02 = 25 RA AVG
- 03 = 20 RA AVG
- 04 = 20 RA AVG AND ELECTROPOLISHED (EP'D)
- 05 = 20 RA AVG, EP'D, ORBITALLY WELDED ASS'Y.
- 06 = 25 RA AVG, ORBITALLY WELDED ASS'Y.

CONNECTION TYPE:

- TH = THREADED
- TC = TRICLAMP
- SW = SOCKET WELD
- BW = BUTT WELD
- SC = COMPRESSION FITTING

LINE NUMBERS:

LINE NUMBERS ARE A THREE DIGIT SEQUENTIAL NUMBER. LINE NUMBERS CHANGE AT THE POINT BETWEEN ANY CHANGE IN SIZE, MATERIAL TYPE, FINISH, OR CONNECTION TYPE.

↓ "SPEC BREAK" INDICATES POINT OF CHANGE IN SPECIFICATION FOR LINE.

EQUIPMENT/COMPONENT DESIGNATIONS

- ASY = ASSEMBLY
- CH = AUTOCLAVE CHAMBER
- CSV = CIRCUIT SETTER VALVE
- DM = DRAIN MANIFOLD
- EJ = EJECTOR PUMP
- F = FILTER
- HX = HEAT EXCHANGER
- LCV = TRAP
- P = PUMP
- PC = PNEUMATIC CYLINDER
- V = VESSEL/TANK
- CV = CHECK VALVE
- HV = HAND (MANUAL) VALVE (NON SPECIFIC)
- ST = STRAINER
- FO = FAIL OPEN
- FC = FAIL CLOSE
- NO = NORMALLY OPEN
- NC = NORMALLY CLOSED

PROCESS AND INSTRUMENTATION LEGEND



APPROVED BY: _____
 DRAWN BY: JWF
 CHECKED BY: JMZ
 DATE: 5-26-2016

THE INFORMATION CONTAINED IN THIS DRAWING IS THE SOLE PROPERTY OF BMT USA, LLC. ANY REPRODUCTION IN PART OR AS A WHOLE WITHOUT THE WRITTEN PERMISSION OF BMT USA, LLC, IS STRICTLY PROHIBITED.

UNLESS OTHERWISE SPECIFIED: CUST.
 DIMENSIONS ARE IN INCHES
 TOLERANCES:
 FRACTIONAL ±1/8
 ANGULAR: BEND ±1°
 TWO PLACE DECIMAL ±.03
 THREE PLACE DECIMAL ±.01

Golden Road Brewing
 DESC. **ELECTRIC CLEAN STEAM GENERATOR 400lbs./hr.**

BMT USA, LLC 14532 169th Dr. SE, Suite 142 Monroe, WA 98272		TEL. 360-863-2252 FAX 360-863-2366 www.bmtus.com	
MODEL #	ECSG400	SERIAL #	SG1641003
DWG. #	B SG1641003-LEGEND	REV	A
SCALE:	WEIGHT:	SHEET 4 OF 4	