

DIP PIPE 'A1' DETAIL  
SCALE: 3"=12"

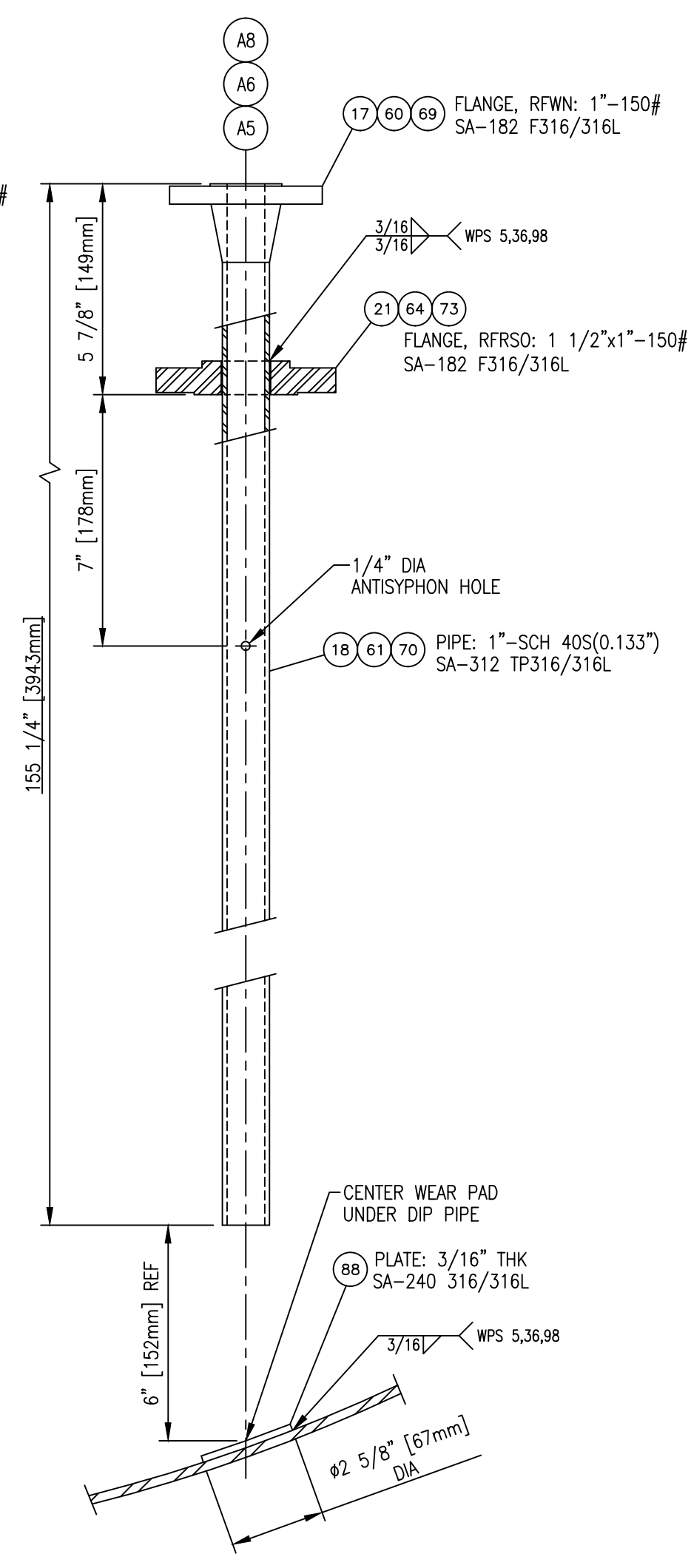

DIP PIPE 'A5', 'A6' & 'A8' DETAIL  
SCALE: 3"=12"

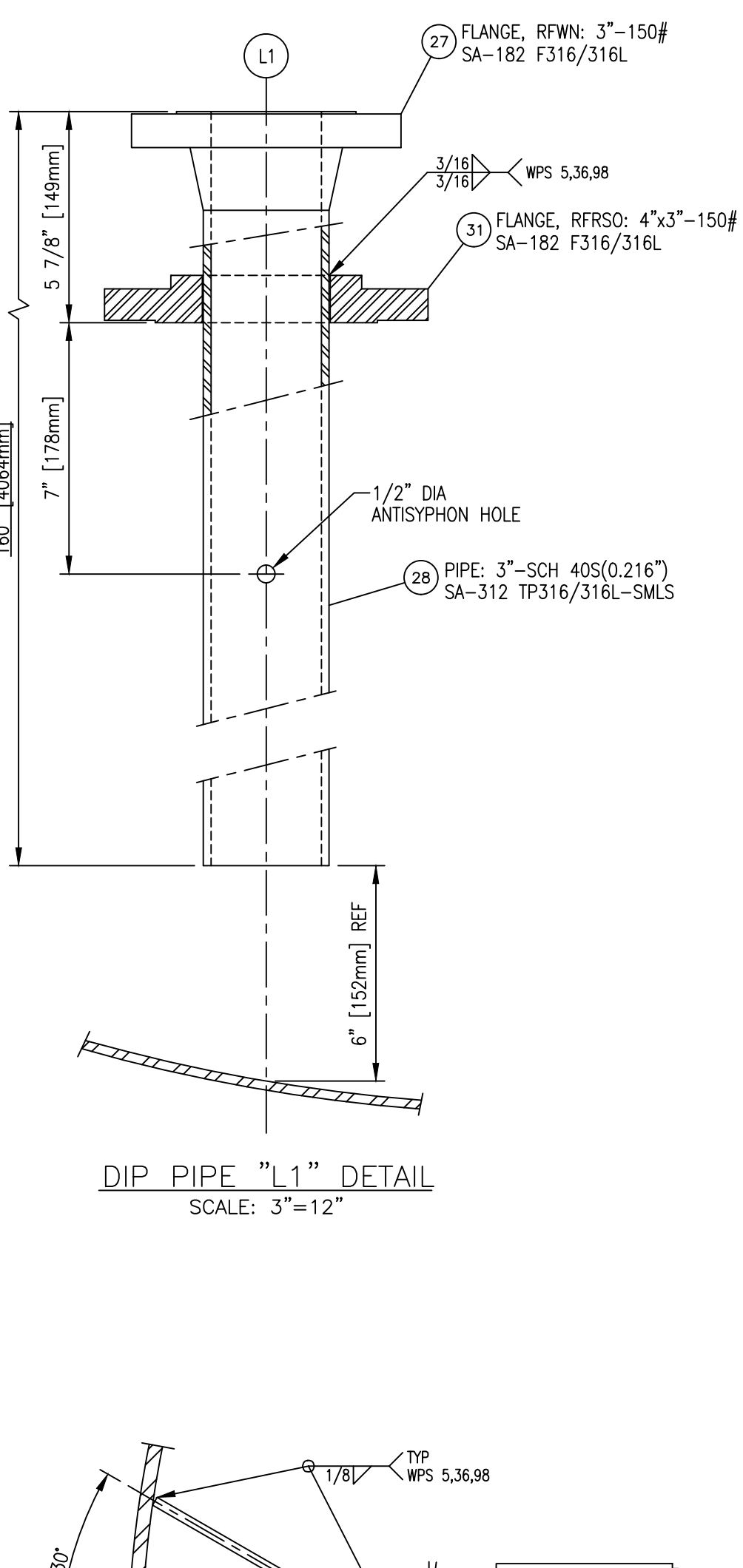

DIP PIPE 'L1' DETAIL  
SCALE: 3"=12"

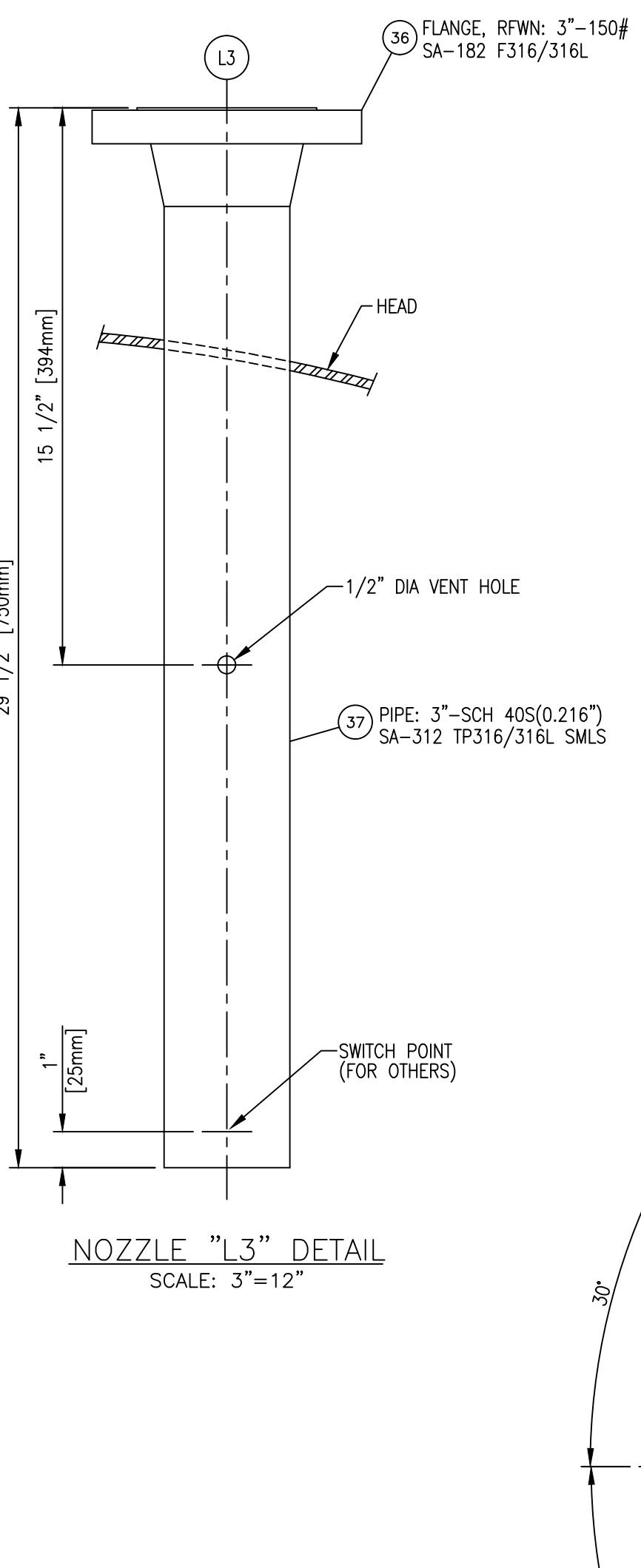

NOZZLE 'L3' DETAIL  
SCALE: 3"=12"

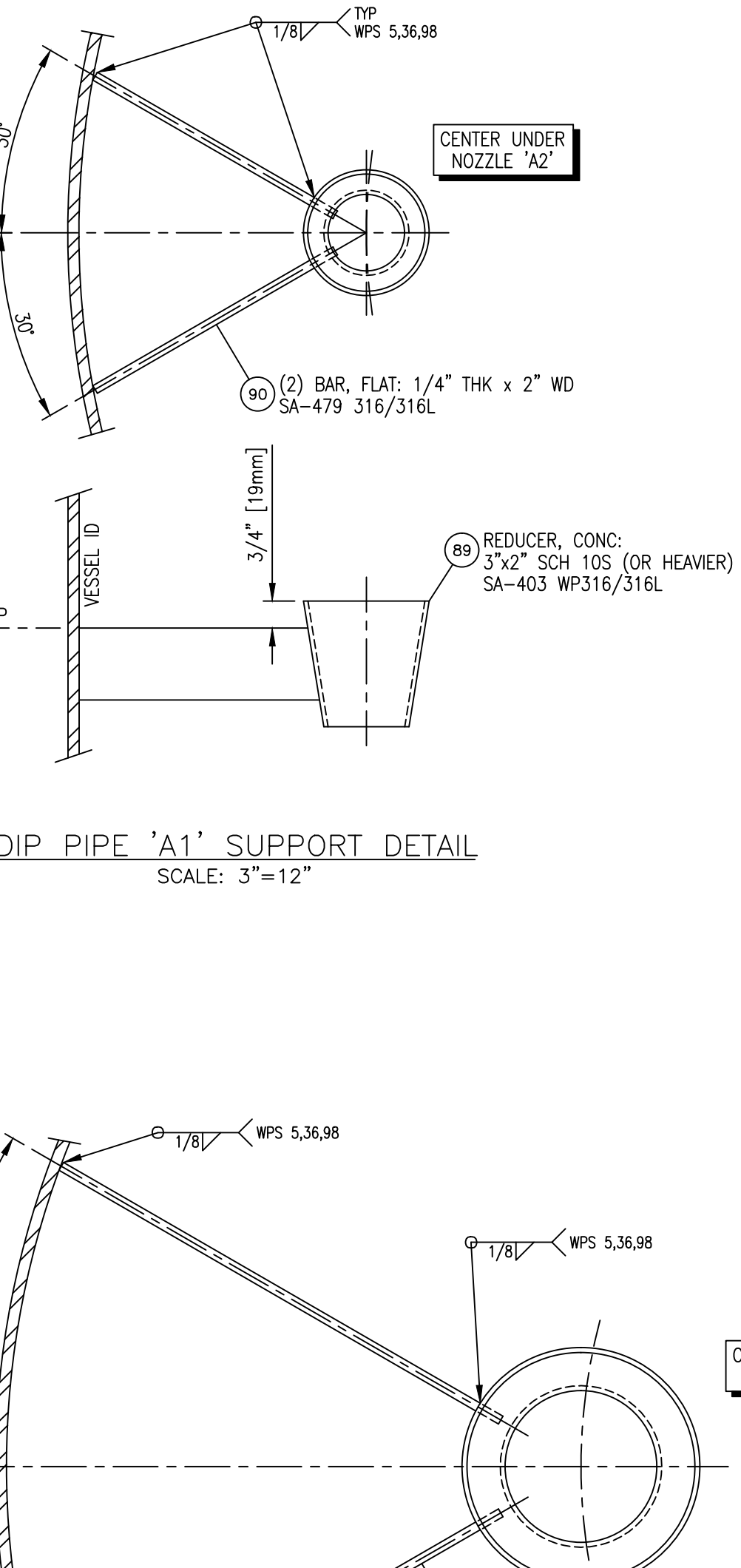

DIP PIPE 'A1' SUPPORT DETAIL  
SCALE: 3"=12"

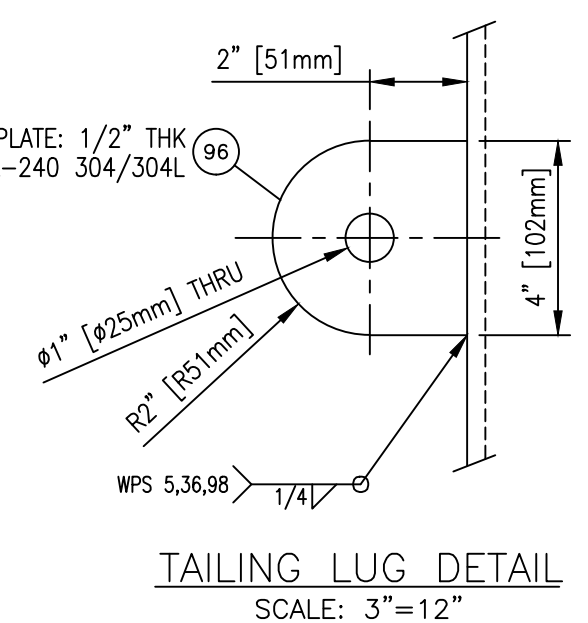

TAILING LUG DETAIL  
SCALE: 3"=12"

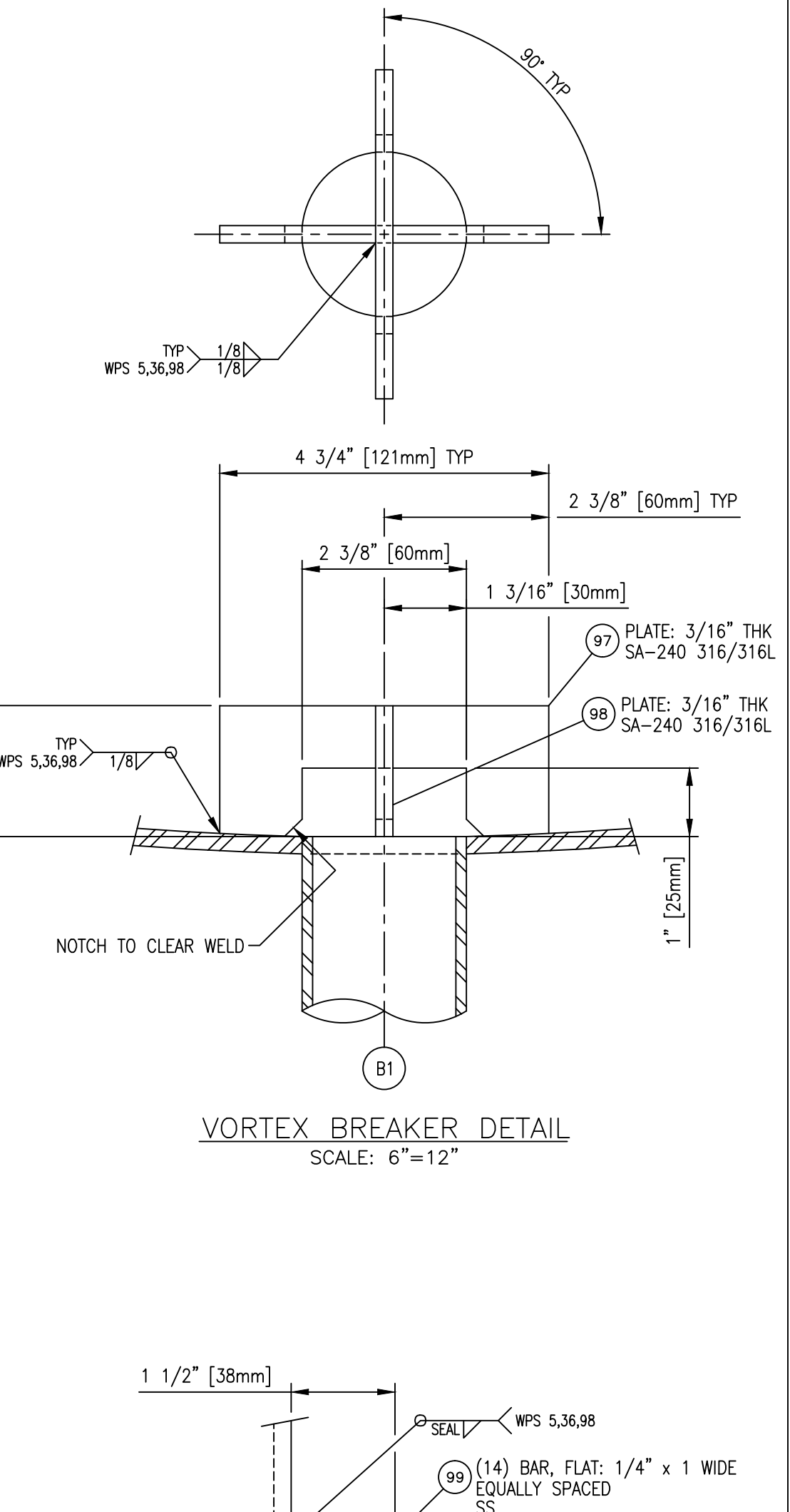

VORTEX BREAKER DETAIL  
SCALE: 6"=12"

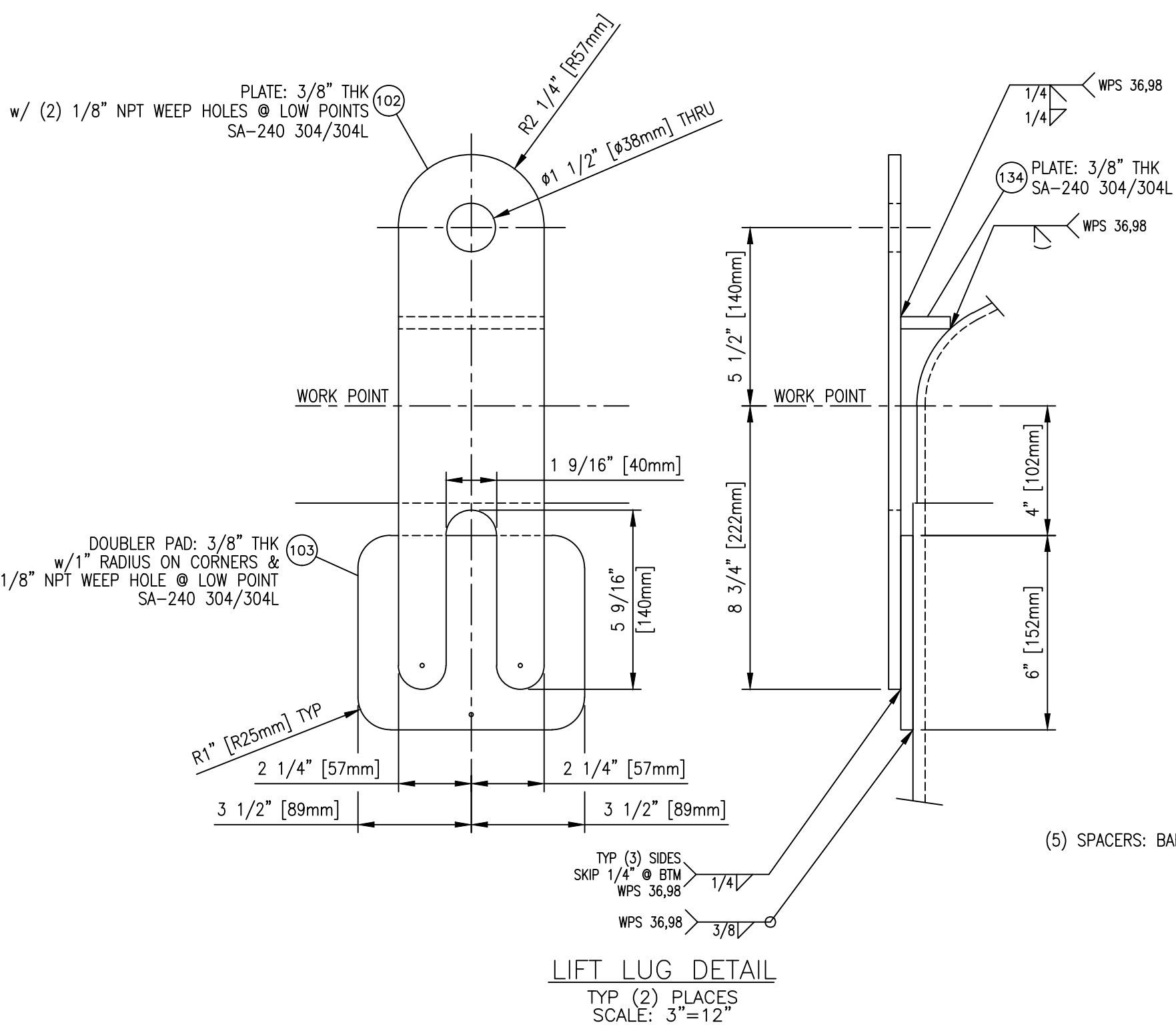

LIFT LUG DETAIL  
TYP (2) PLACES  
SCALE: 3"=12"

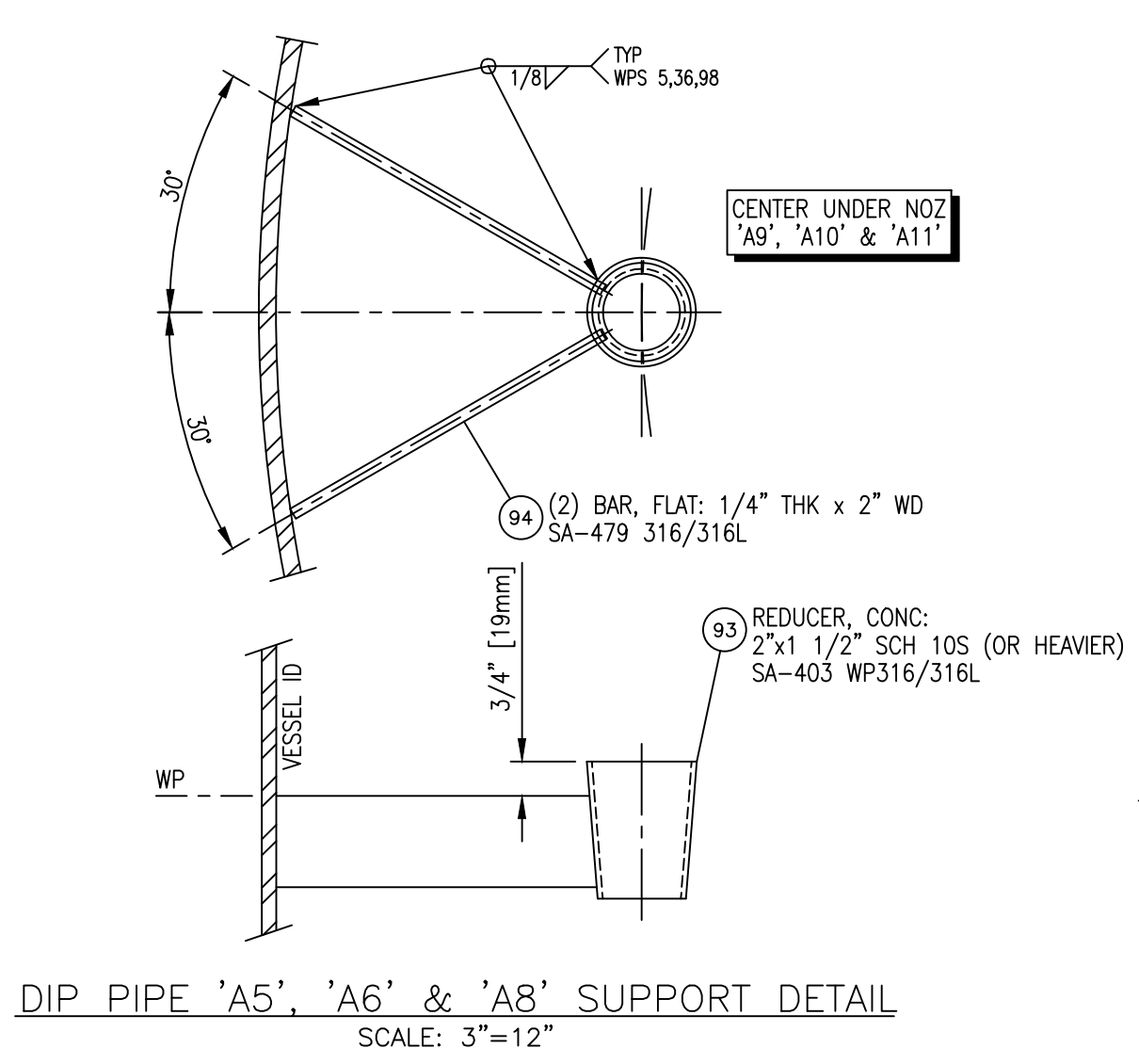

DIP PIPE 'A5', 'A6' & 'A8' SUPPORT DETAIL  
SCALE: 3"=12"

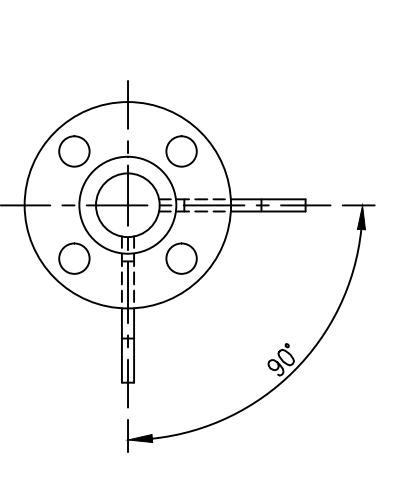

TYPICAL NOZZLE GUSSET DETAIL  
TYP (4) PLACES  
SCALE: 3"=12"

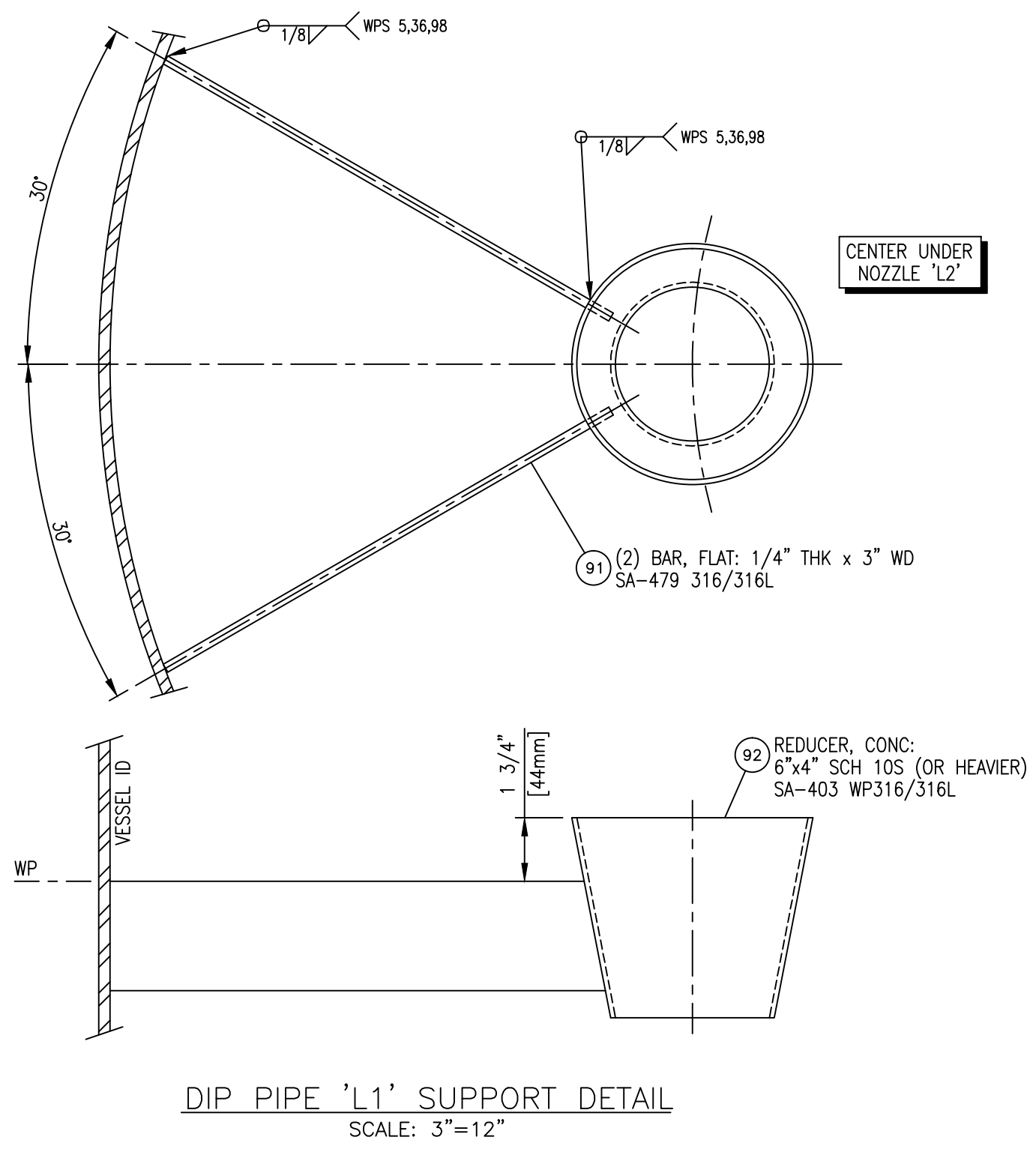

DIP PIPE 'L1' SUPPORT DETAIL  
SCALE: 3"=12"

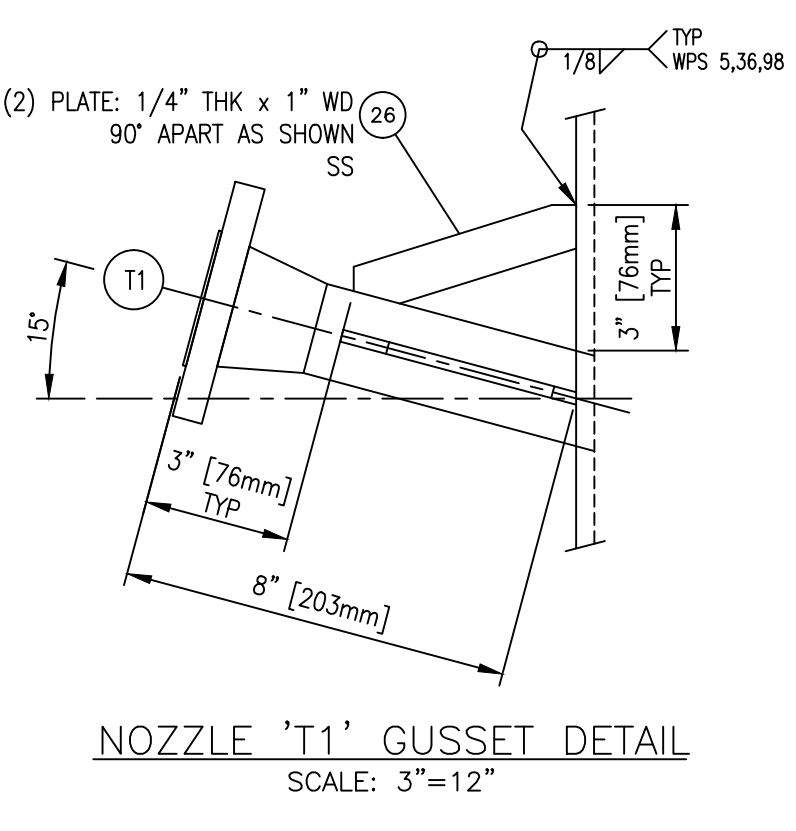

NOZZLE 'T1' GUSSET DETAIL  
SCALE: 3"=12"

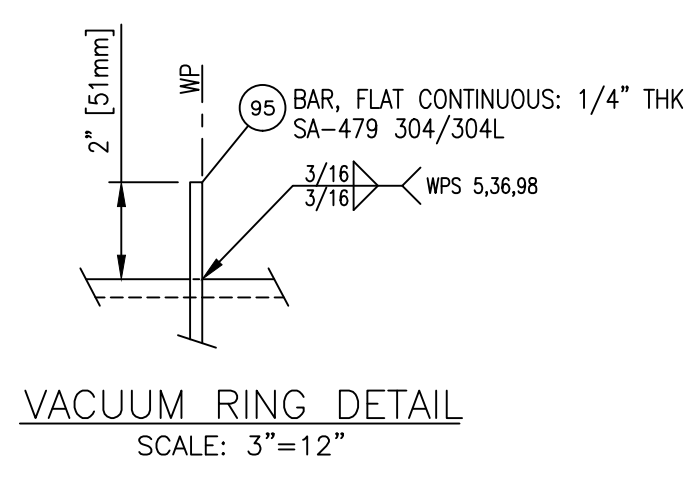

VACUUM RING DETAIL  
SCALE: 3"=12"

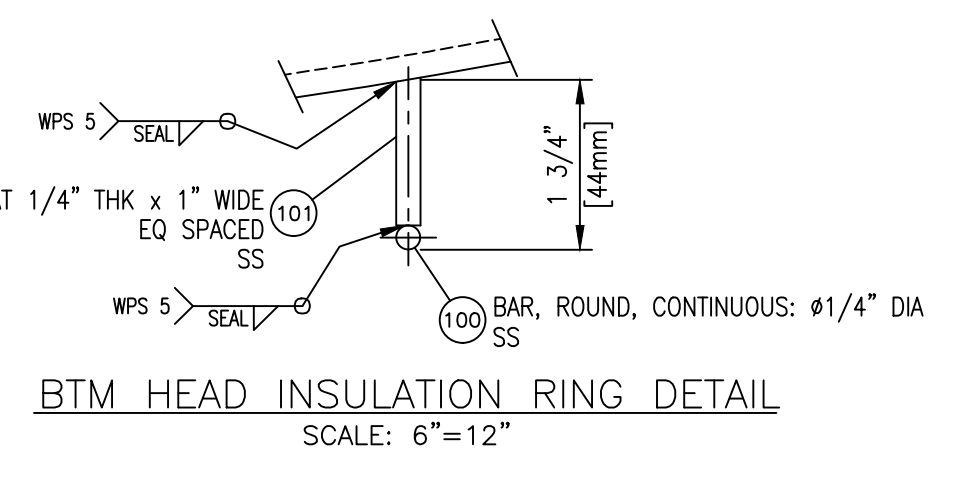

BTM HEAD INSULATION RING DETAIL  
SCALE: 6"=12"

**CERTIFIED/SHOP PRINT**  
WARD TANK AND HEAT EXCHANGER CORP  
By: JOHN WYATT  
Date: 9/9/2015  
WTC REQUESTS THAT DRAWINGS BE RETURNED (ONLY IF REQUIRED) IN HARD COPY FORM ONLY. MODIFIED DRAWINGS MUST BE RETURNED IMMEDIATELY TO WTC FOR FABRICATION UPDATE.

REV NO.	DATE	DESCRIPTION	BY
5	10/8/2015	NO CHANGES THIS PAGE / ISSUE FOR FAB	JRW
4	9/25/2015	NO CHANGES THIS PAGE / ISSUE FOR FAB	JRW
3	9/9/2015	REVISED PER CUST COMMENTS / ISSUE FOR FAB	DSG
2	8/26/2015	REVISED PER CUST COMMENTS / ISSUE FOR FAB	DSG
1	5/14/2015	REVISED PER CUSTOMER COMMENTS / FOR APPROVAL	JRW
0	2/19/2015	FOR CUSTOMER APPROVAL	JRW

THIS DRAWING IS THE PROPERTY OF WARD TANK AND HEAT EXCHANGER CORP ("WARD") AND THE BELOW NAMED CUSTOMER. THIS DRAWING IS ONLY TO BE USED IN REFERENCE TO WORK PROPOSED OR CONTRACTED BY EITHER WARD OR THE BELOW NAMED CUSTOMER AND ITS AFFILIATES AND/OR ON BEHALF OF WARD OR THE BELOW NAMED CUSTOMER AND ITS AFFILIATES. IT MUST NOT BE REPRODUCED OR SUBMITTED TO OUTSIDE PARTIES WITHOUT THE WRITTEN PERMISSION FROM WARD OR FROM THE BELOW NAMED CUSTOMER.

		<b>WARD TANK AND HEAT EXCHANGER CORP</b> 6670 E. HARRIS BLVD. CHARLOTTE, NC 28215	
CUSTOMER	EVONIK CORP THEODORE, AL	PURCHASE ORDER NUMBER	4700898293
TITLE <b>48" ID X 138" CRUDE ACA FEED TANK</b>			
EQUIPMENT NO.	V-4310	SCALE	AS NOTED
APPROVED BY	JRW	DATE	8/26/2015
DRAWN BY	DSG	DATE	2/18/2015
NO REQ'D	1	REV. NO.	5
		DRAWING NUMBER	2015-WC-9192
		SHEET 2 OF 3	

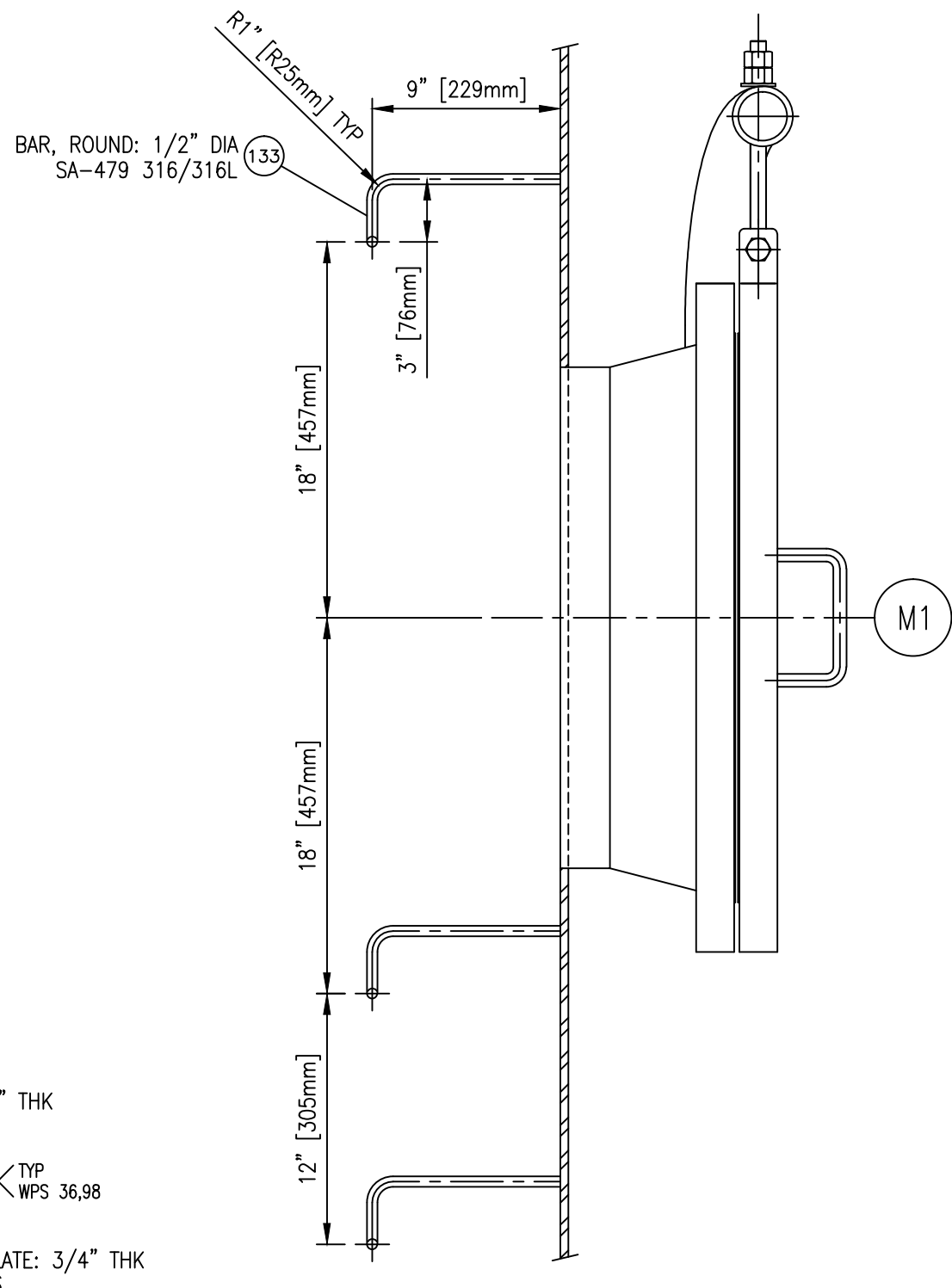
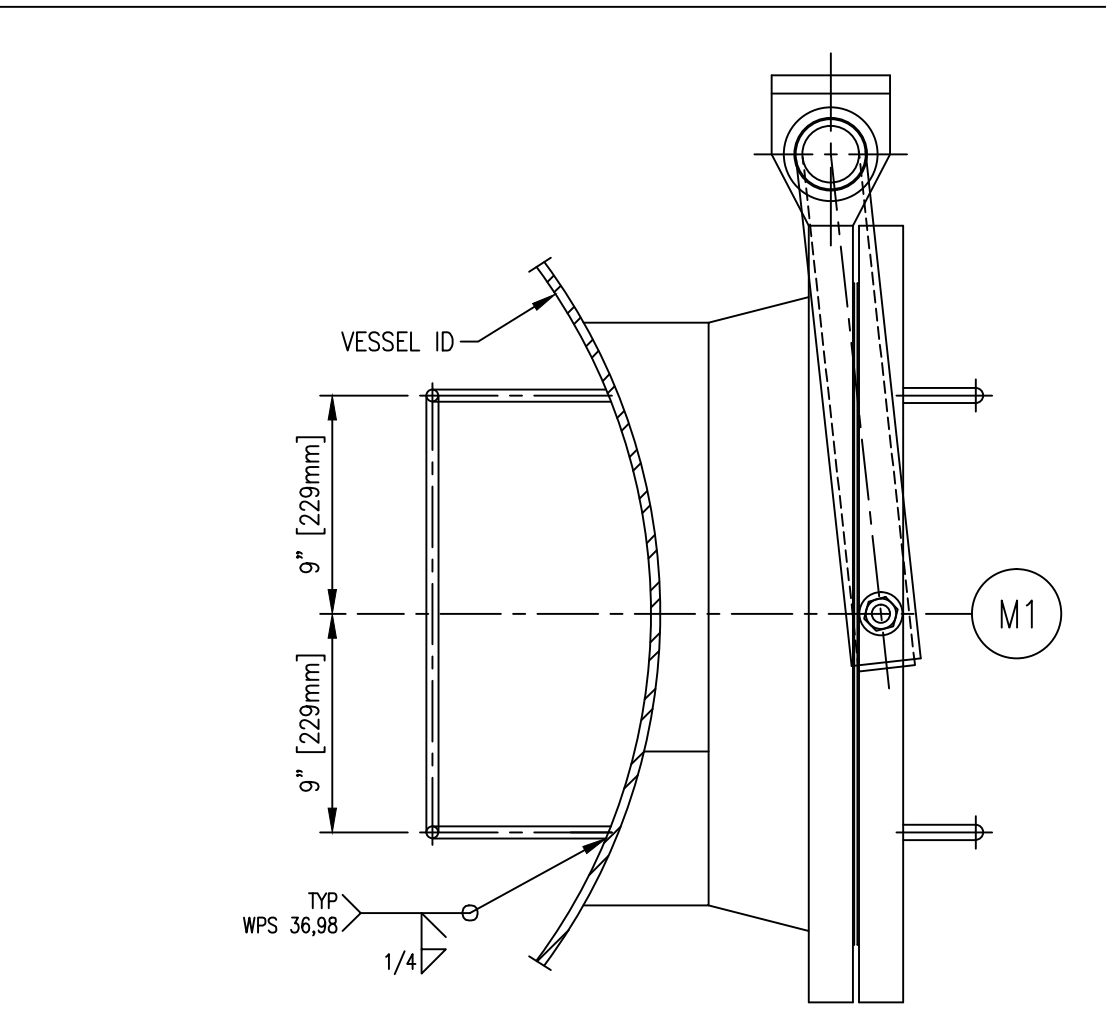
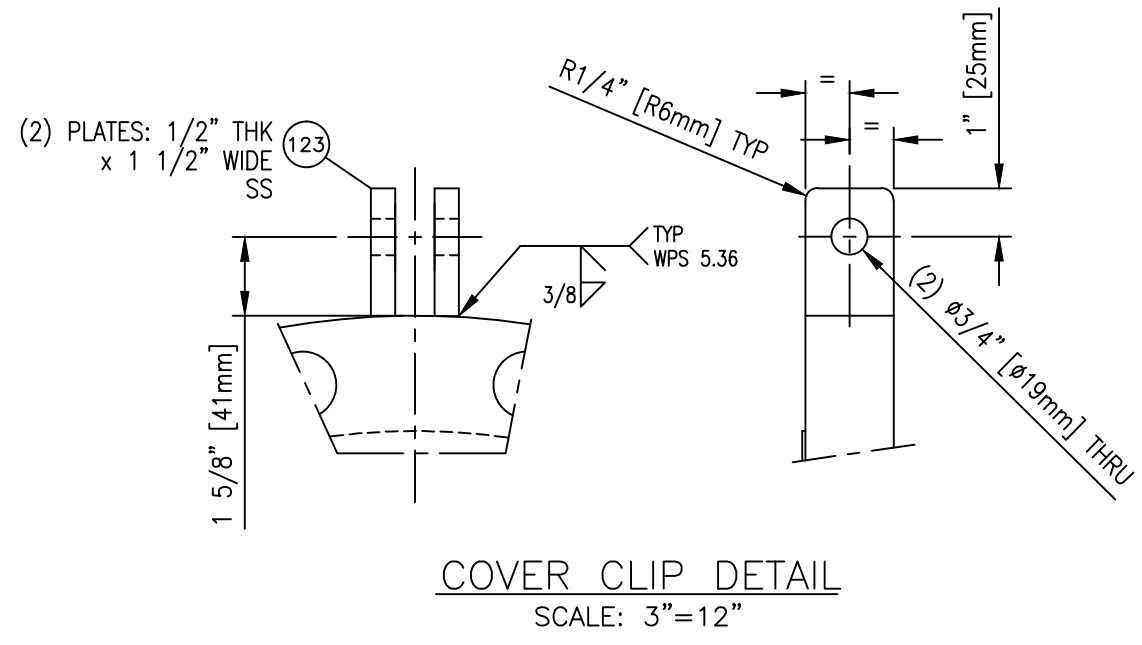
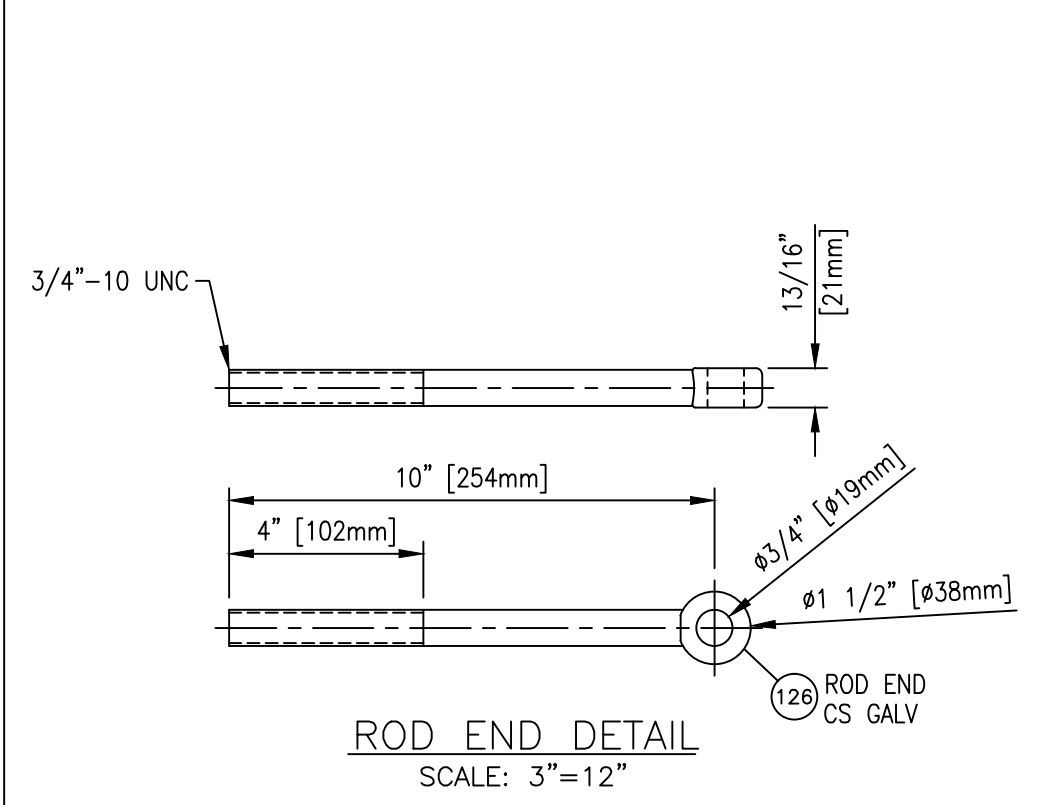
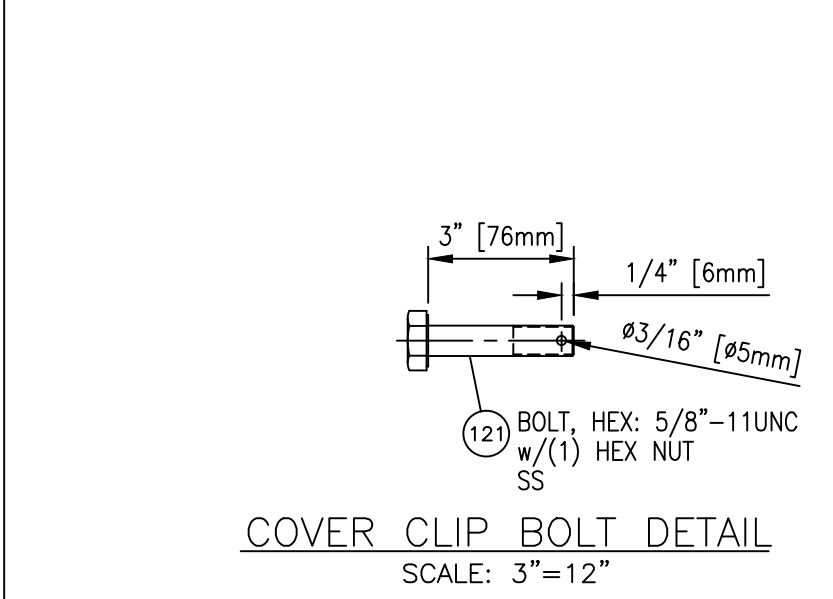
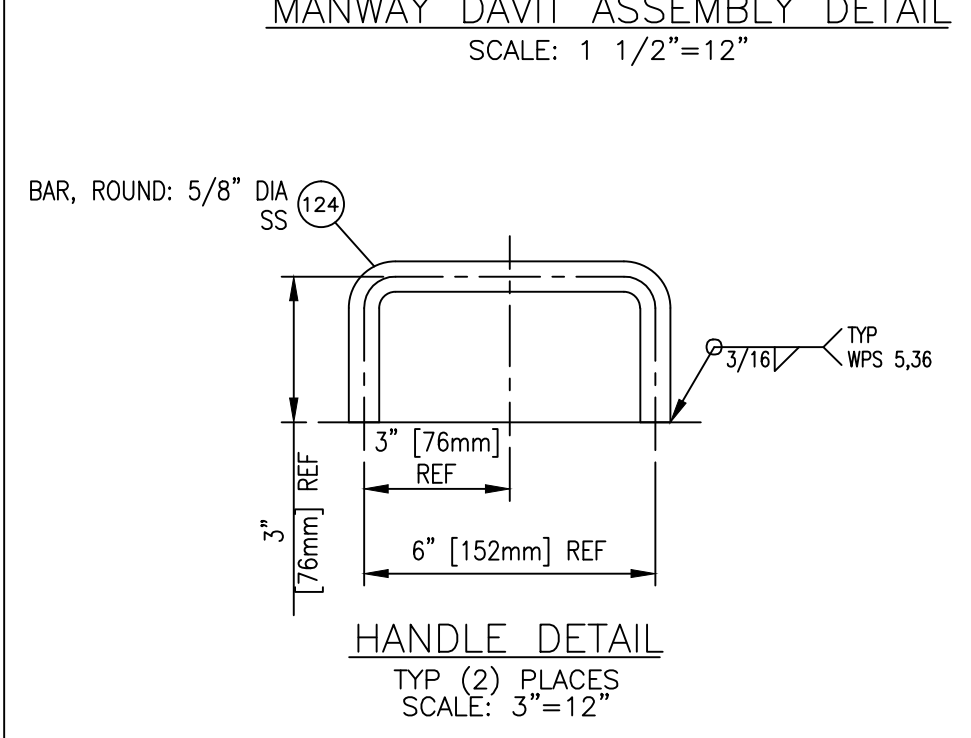
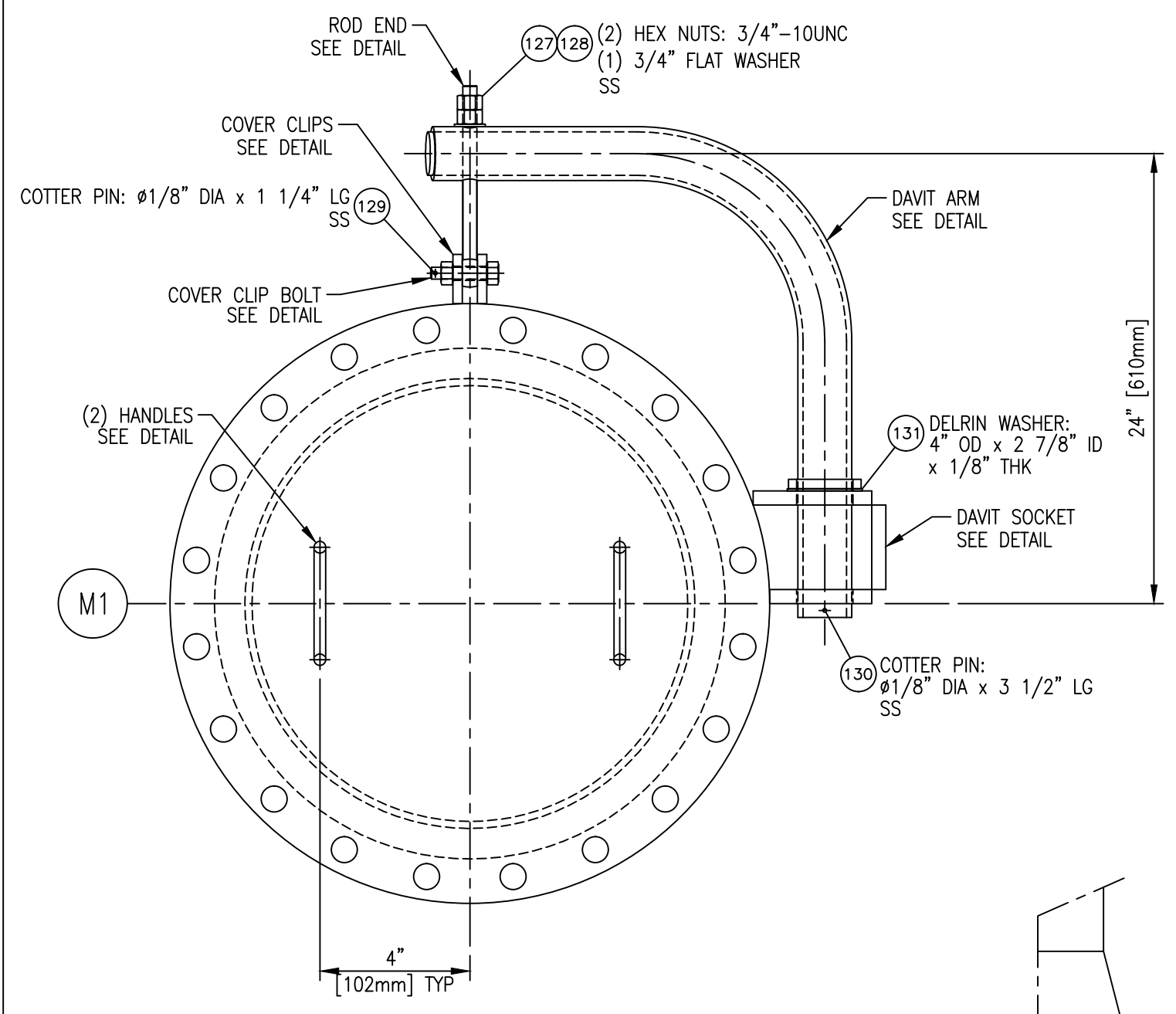
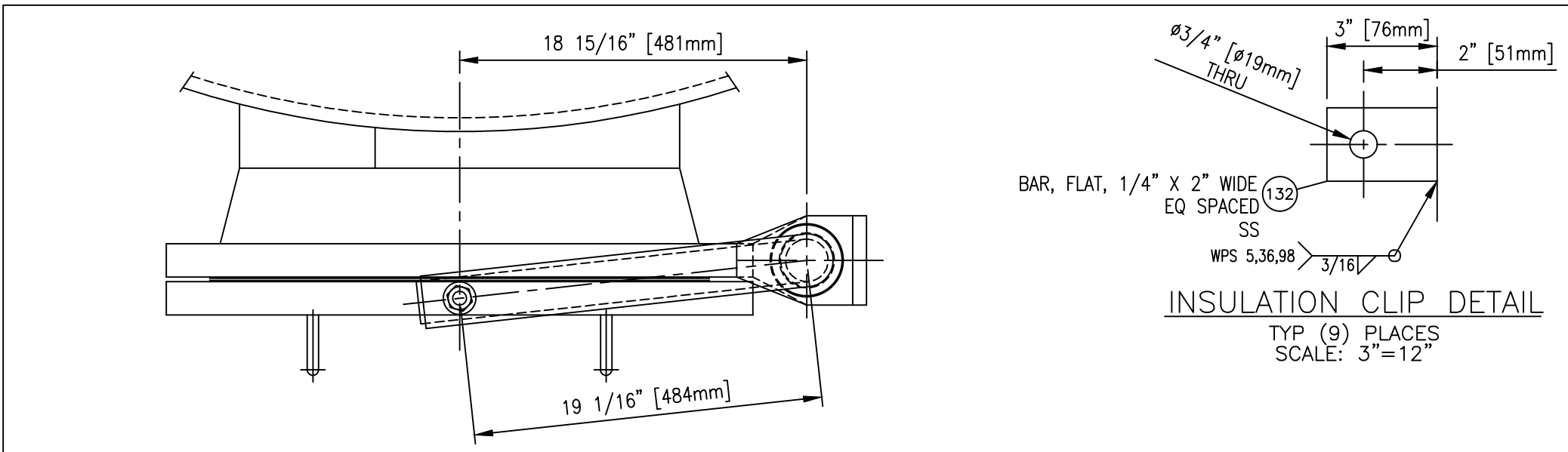

**INTERNAL GRAB RUNG DETAIL**  
 SCALE: 1 1/2"=12"

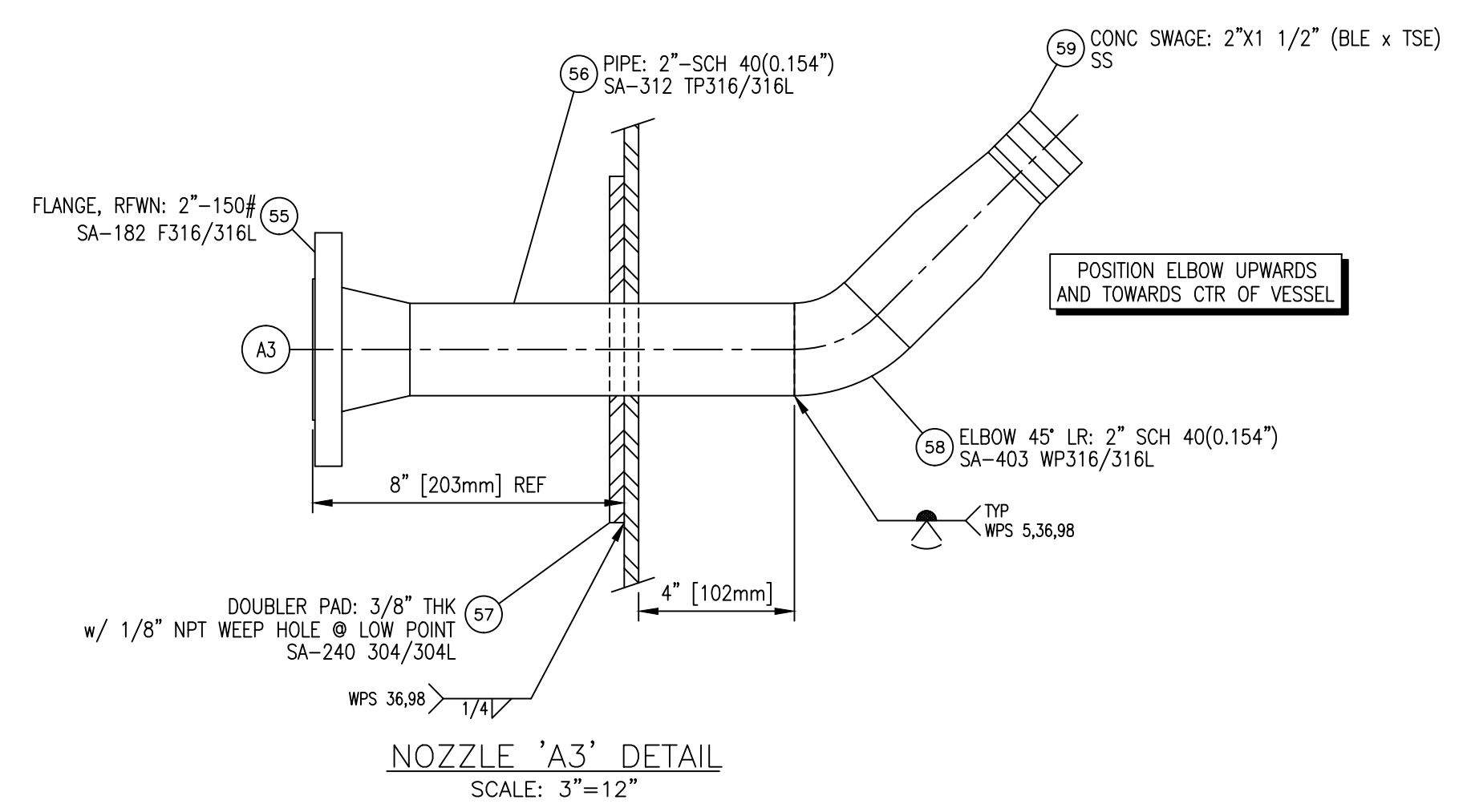

**NOZZLE 'A3' DETAIL**  
 SCALE: 3"=12"

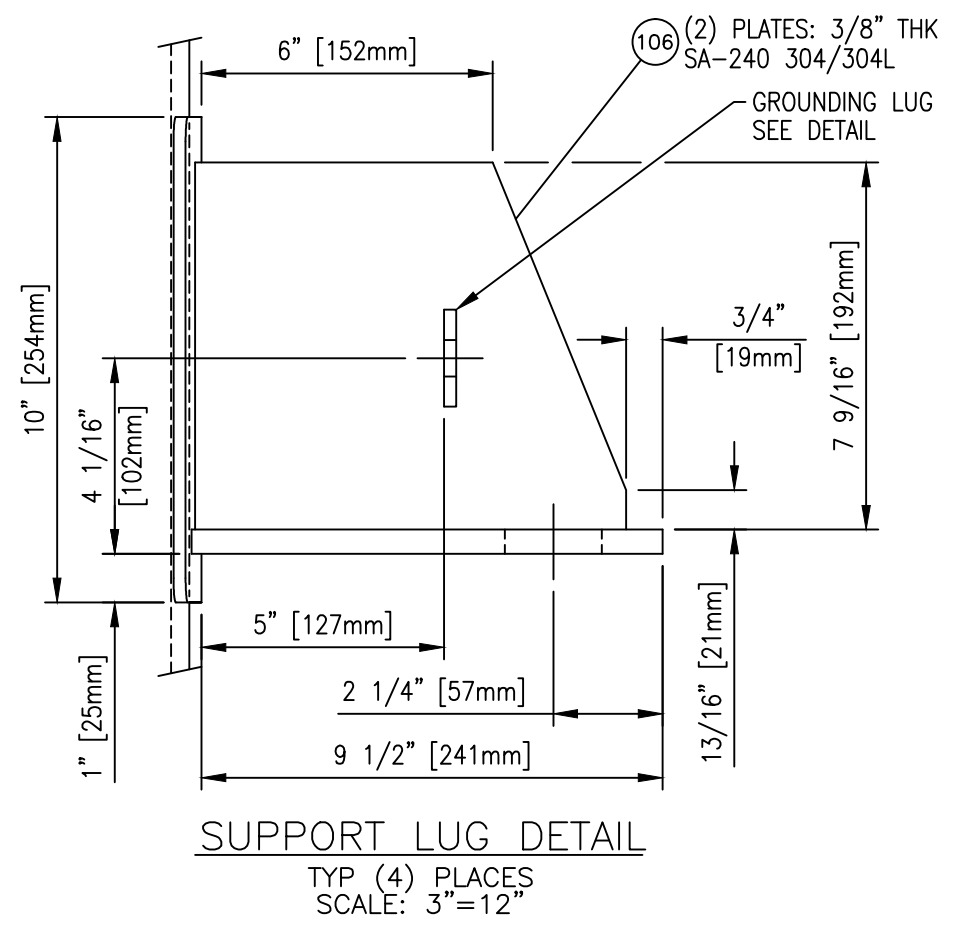
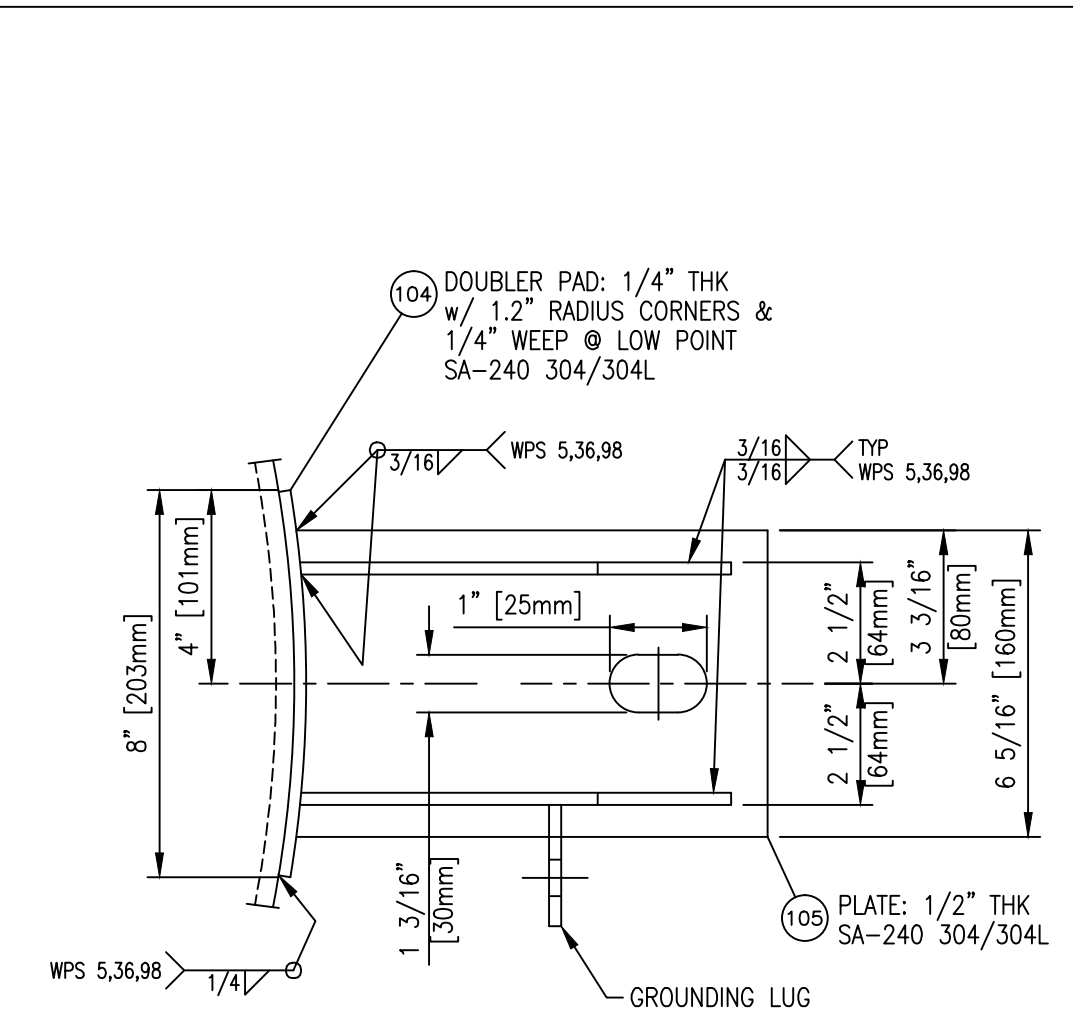

**SUPPORT LUG DETAIL**  
 TYP (4) PLACES  
 SCALE: 3"=12"

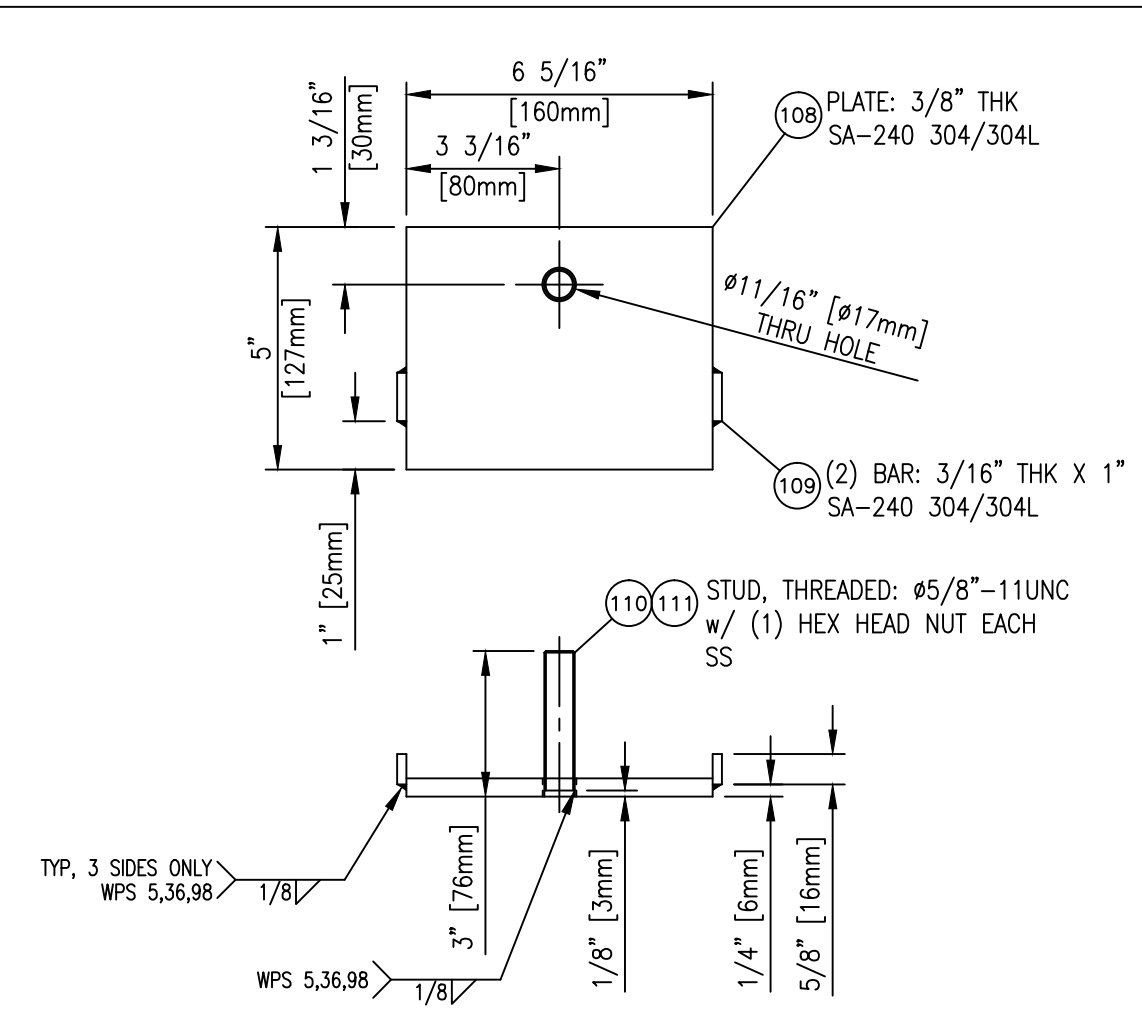

**WELD PLATE DETAIL**  
 TYP (4) PLACES (SHIP LOOSE)  
 SCALE: 3"=12"

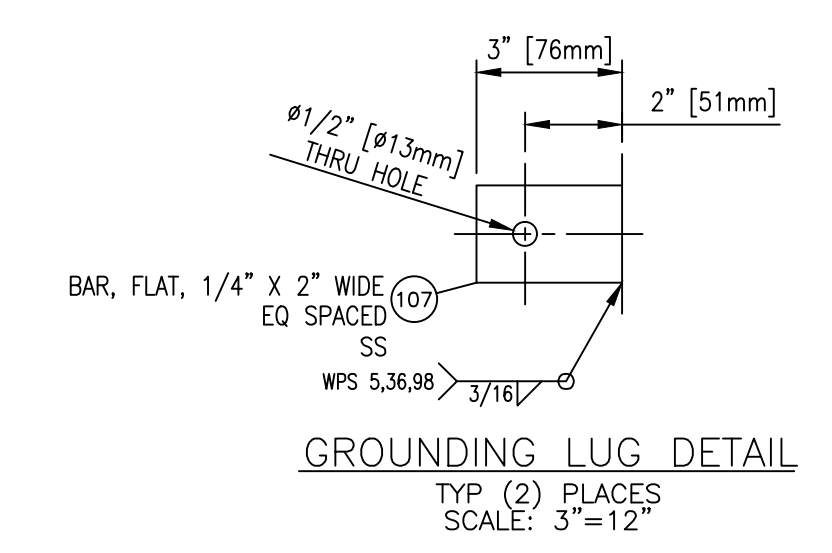

**GROUNDING LUG DETAIL**  
 TYP (2) PLACES  
 SCALE: 3"=12"

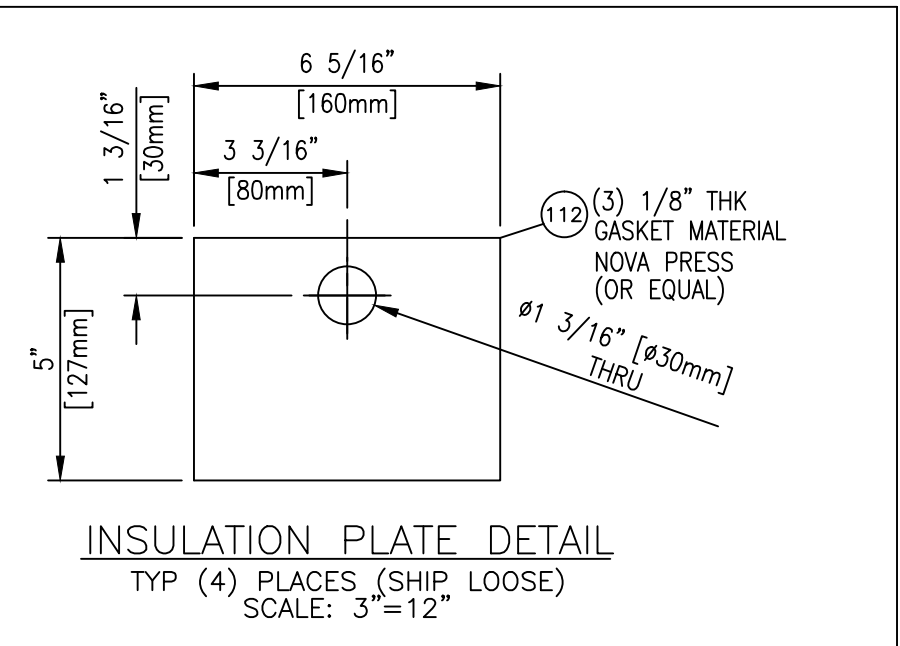

**INSULATION PLATE DETAIL**  
 TYP (4) PLACES (SHIP LOOSE)  
 SCALE: 3"=12"

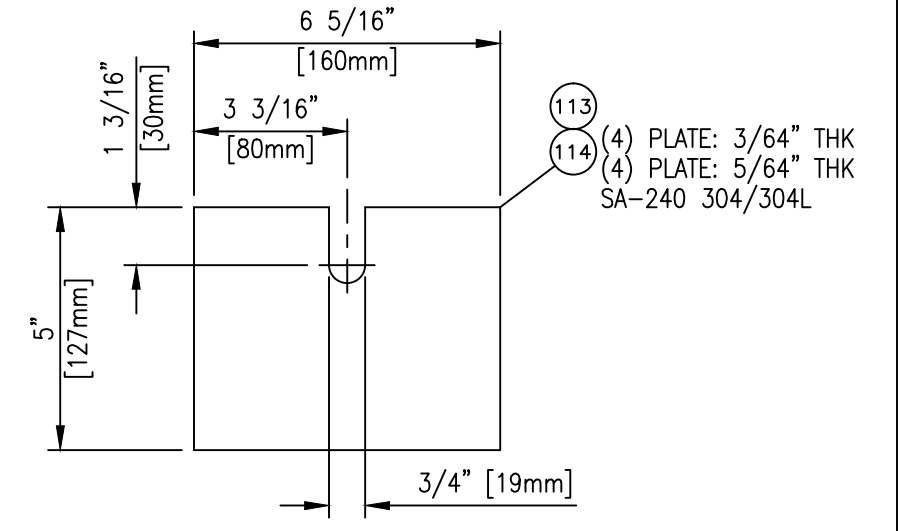

**ADJUSTING PLATE DETAIL**  
 TYP (8) PLACES (SHIP LOOSE)  
 SCALE: 3"=12"

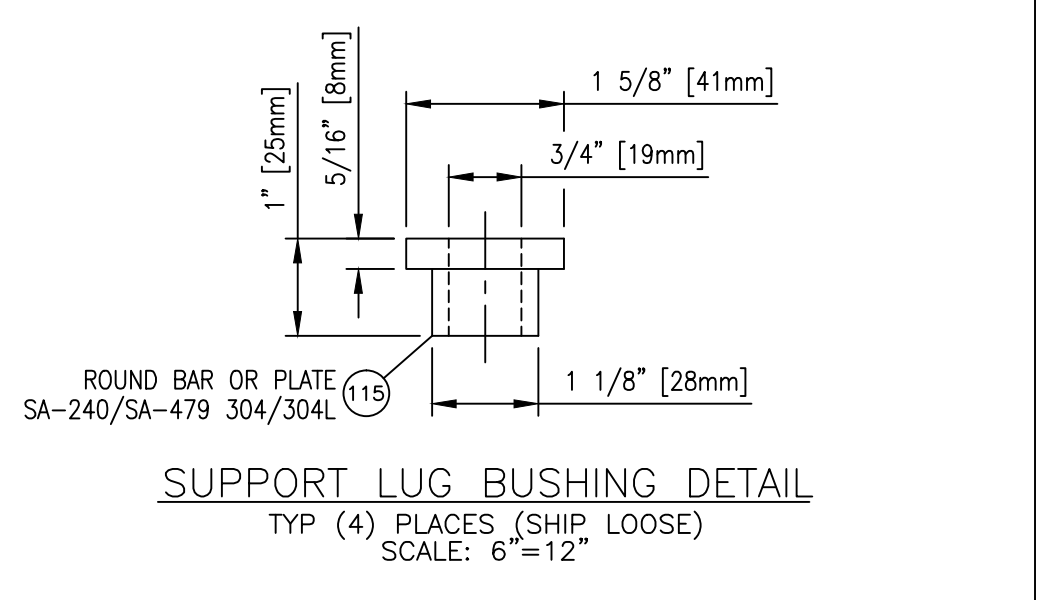

**SUPPORT LUG BUSHING DETAIL**  
 TYP (4) PLACES (SHIP LOOSE)  
 SCALE: 6"=12"

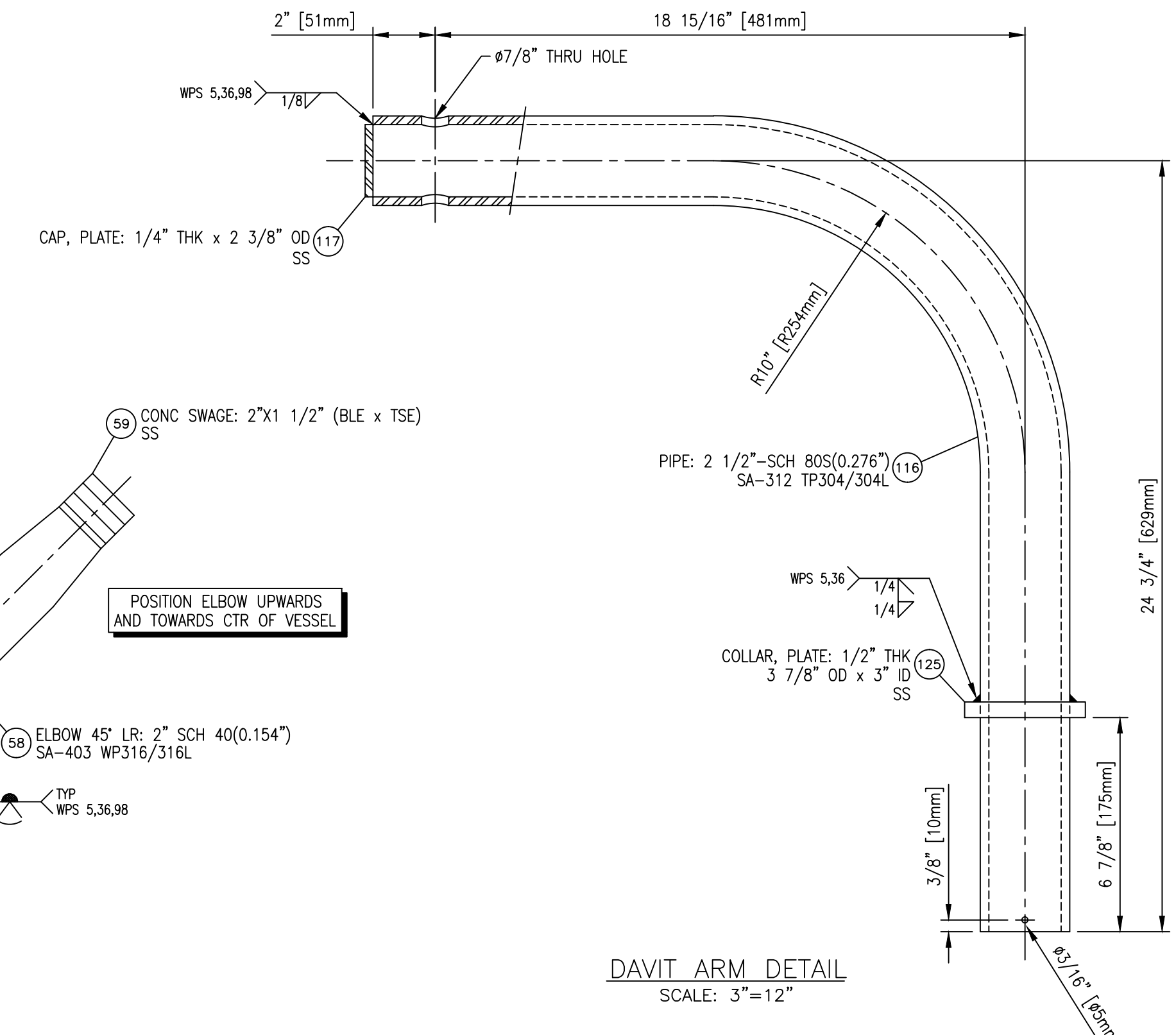

**DAVIT ARM DETAIL**  
 SCALE: 3"=12"

**CERTIFIED/SHOP PRINT**  
 WARD TANK AND HEAT EXCHANGER CORP  
 By: JOHN WYATT  
 Date: 9/9/2015

WTC REQUESTS THAT DRAWINGS BE RETURNED (ONLY IF REQUIRED) IN HARD COPY FORM ONLY. MODIFIED DRAWINGS MUST BE RETURNED IMMEDIATELY TO WTC FOR FABRICATION UPDATE.

REV NO.	DATE	DESCRIPTION	BY
5	10/8/2015	NO CHANGED THIS PAGE / ISSUE FOR FAB	JRW
4	9/25/2015	NO CHANGED THIS PAGE / ISSUE FOR FAB	JRW
3	9/9/2015	REVISED PER CUST COMMENTS / ISSUE FOR FAB	DSG
2	8/26/2015	REVISED PER CUST COMMENTS / ISSUE FOR FAB	DSG
1	5/14/2015	REVISED PER CUSTOMER COMMENTS / FOR APPROVAL	DSG
0	2/19/2015	FOR CUSTOMER APPROVAL	JRW

THIS DRAWING IS THE PROPERTY OF WARD TANK AND HEAT EXCHANGER CORP ("WARD") AND THE BELOW NAMED CUSTOMER. THIS DRAWING IS ONLY TO BE USED IN REFERENCE TO WORK PROPOSED OR CONTRACTED BY EITHER WARD OR THE BELOW NAMED CUSTOMER AND ITS AFFILIATES AND/OR ON BEHALF OF WARD OR THE BELOW NAMED CUSTOMER AND ITS AFFILIATES. IT MUST NOT BE REPRODUCED OR SUBMITTED TO OUTSIDE PARTIES WITHOUT THE WRITTEN PERMISSION FROM WARD OR FROM THE BELOW NAMED CUSTOMER.

<b>WARD TANK AND HEAT EXCHANGER CORP</b> 6670 E. HARRIS BLVD. CHARLOTTE, NC 28215	
CUSTOMER: EVONIK CORP THEODORE, AL	PURCHASE ORDER NUMBER: 4700898293
TITLE: 48" ID X 138" CRUDE ACA FEED TANK	
EQUIPMENT NO. V-4310	SCALE AS NOTED
APPROVED BY: JRW	DATE: 8/26/2015
DRAWN BY: DSG	DATE: 2/18/2015
NO REQ'D: 1	REV. NO: 5
DRAWING NUMBER: 2015-WC-9192	
SHEET 3 OF 3	