

Thermatrix Inc.

OPERATION MANUAL

**Thermatrix Inc. Electric
Straight Through
Thermal Oxidizer**

Document:
TE4172-C31

Revision: 0

**THERMATRIX ES™
ELECTRIC STRAIGHT THROUGH
FLAMELESS THERMAL OXIDIZER SYSTEM**

**FIELD SERVICE
COPY**

Volume I

Thermatrix Inc.

TABLE OF CONTENTS

1 INTRODUCTION..... 1

1.1 Purpose..... 1

1.2 Contacting Thermatrix 1

1.3 Responsibility..... 1

1.4 Conventions..... 2

1.5 DEFINITIONS 2

2 OPERATING GUIDELINES 3

2.1 PROCESS CONTROL GUIDELINES 3

2.2 startup operator instructions..... 4

2.3 equipment operating status 5

2.4 TYPICAL INSTRUMENT READINGS..... 6

3 OPERATING STEPS 7

3.1 Preheat STEP..... 8

3.1.1 Sequence Entry..... 8

3.1.2 Control Step Permissives..... 8

3.1.3 Shutdown Interlocks..... 8

3.1.4 Alarms 9

3.1.5 Operator Actions 9

3.1.6 PLC Actions 9

3.1.7 Sequence End Point Conditions 9

3.1.8 Sequence Exit..... 9

3.1.9 Automatic Block Valve and Power Contactor Status..... 10

3.1.10 Controller and Control Valve Activities..... 10

3.2 Run STEP..... 11

3.2.1 Sequence Entry..... 11

3.2.2 Control Step Permissives..... 11

3.2.3 Shutdown Interlocks..... 11

3.2.4 Alarms 12

3.2.5 Operator Actions 12

3.2.6 PLC Actions 12

3.2.7 Sequence End Point Conditions 12

3.2.8 Sequence Exit..... 12

3.2.9	Automatic Block Valve and Power Contactor Status.....	13
3.2.10	Controller and Control Valve Activities.....	13
3.3	Shutdown STEP.....	14
3.3.1	Sequence Entry.....	14
3.3.2	Control Step Permissives.....	14
3.3.3	Shutdown Interlocks.....	14
3.3.4	Alarms.....	14
3.3.5	Operator Actions.....	14
3.3.6	PLC Actions.....	14
3.3.7	Sequence End Point Conditions.....	15
3.3.8	Sequence Exit.....	15
3.3.9	Automatic Block Valve and Power Contactor Status.....	15
3.3.10	Controller and Control Valve Activities.....	15
4	REFERENCE INFORMATION.....	16
4.1	Instrument Index.....	16
4.2	Equipment Index.....	17
4.3	Line Index.....	17
4.4	System Outline Drawing.....	18
5	INSTALLATION DETAIL.....	20

Thermatrix Inc.

OPERATION MANUAL

**Thermatrix Inc. Electric
Straight Through
Thermal Oxidizer**

Document:
TE4172-C31

Revision: 0

REVISION SUMMARY

VERSION	DATE	DESCRIPTION	BY	REVIEWED	PROJECT
0	10/13/03	Certified	ARV	<i>CR James</i>	<i>L. M. Castiglioni</i>

PLC is a registered trademark of Allen-Bradley Company, Inc.
Thermatrix is a registered trademark and ES is a trademark of Thermatrix Inc.

1 INTRODUCTION

1.1 PURPOSE

This manual has been prepared to serve as a general guide for operating the flameless thermal oxidation system furnished by Thermatrix. It is intended for use by qualified personnel with knowledge of industrial heating equipment. Personnel should read and understand all instructions and become thoroughly familiar with the equipment before beginning any operating procedure. The owner's operating personnel are responsible for proper operation of the equipment, including specifications and limitations of the "Design Criteria Document" pertaining to this piece of equipment. The owner and operator must understand that the instructions and stated warnings do not cover every operational variation.

1.2 CONTACTING THERMATRIX

If additional information is required, or if you have any questions about the proper operation of the Thermatrix ES (Electric Straight-through) Flameless Thermal Oxidizer or any other Thermatrix product, please contact us at the address and phone numbers listed below

Thermatrix Inc.
Five Sentry Parkway East
Blue Bell, PA 19422
Ph: (610) 834-0300
Fax (610) 834-0473

1.3 RESPONSIBILITY

-WARNING-

Thermatrix offers no warranty, either expressed or implied, of equipment integrity or performance, if said equipment is not operated in accordance with the instructions and specifications contained within this document. Equipment operating within or containing flammable or combustible atmospheres and in association with high temperatures, flames, ignition sources, or electrical power present inherent dangers which require care and caution from all personnel. It is the responsibility of the owner to follow the instructions in this document and to exercise other normal and reasonable care in order to prevent injury to personnel, property damage, or interruptions of normal operation.

1.4 CONVENTIONS

To help locate and interpret information easily, this manual uses consistent conventions as follows.

<u><i>This</i></u>	<u><i>Represents</i></u>
-WARNING-	Calls attention to instructions where there is increased danger of personal injury.
-CAUTION-	Indicates extra care is required to avoid damage to property or equipment.
-NOTICE-	Calls special attention to the instruction.

1.5 DEFINITIONS

The following definitions are used routinely in the text of this document.

<u><i>This</i></u>	<u><i>Means</i></u>
DI	Discrete input
DO	Discrete output
ESD	Emergency shutdown
ES	Electric straight-through flameless thermal oxidizer system
LCD	Liquid crystal display
Lean	Containing fuel value insufficient to sustain combustion
N/A	Not applicable
Owner	Purchaser or lessee of the system
Operator	Owner, owner's employees or owner's designated agent
Permissive	Condition(s) required to proceed to the next step or activity
PLC	Programmable logic controller
Rich	Containing fuel value sufficient to sustain combustion
SS	Software switch
TBD	To be determined
VOC	Volatile organic compound
SLC	Single loop controller

2 OPERATING GUIDELINES

2.1 PROCESS CONTROL GUIDELINES

The Thermatrix flameless oxidation process is based on a patented matrix that enhances the oxidation process. The matrix is a carefully designed volume of inert ceramic media selected for its thermal properties. Equipment and instrument tag numbers may be found on Piping and Instrumentation Drawing TE-4172-P40-01. The design flow rates for the thermal oxidation system are shown on Process Flow Diagram ES100-P30-01 (see Appendix). The ES-100 oxidizer is designed for operation below the lower flammability limit and with sufficient oxygen to complete oxidation. The maximum flow rate to the ES-100 for a lean fume stream is 85 scfm (0 BTU/SCF), and is capable of handling up to 140 scfm of a rich fume stream (30 BTU/SCF).

The tie point for the fume collection system is at the edge of the Thermatrix system. The fume enters the ES-100 skid through an air operated block valve (XV-210) and the flow is indicated by a rotameter, FI-210. The fume flows through a flame arrestor prior to entering the bottom of the oxidizer. Dilution air is required to maintain the proper oxidizer operation. This is automatically accomplished by cooling the bottom of the oxidizer when the lower bed temperature (TE-310B) is high. A regenerative blower (B-230) is used to supply this dilution air. The flow rate of air to the oxidizer is measured to provide local indication. An air-actuated block valve (XV-230) is opened when the blower (B-230) is energized.

The oxidizer shell is fabricated of carbon steel and lined with a refractory blanket that reduces the external skin temperature suitable for the electrical area classification. The oxidizer has three internal vertical protection tubes that house the heating elements. A single vertical thermowell in the bed is also provided to monitor the temperature profile of the ceramic matrix. The oxidizer contains randomly-packed ceramic saddles which fill the oxidizer from the bottom to 6 inches above the top of the protection tubes. During startup, the cold ceramic media is heated using the electrically controlled heaters. The heaters operate during the run mode to enhance low BTU fume streams.

The gas mixture enters a nozzle on the bottom of the oxidizer and flows upward through the media. The oxidation reaction takes place at the heated region of the protection tubes (upper 2/3rds). The reaction occurs rapidly. Within an 8 to 12 inch zone, the temperature rises from the inlet temperature to the full operating temperature. Hydrocarbons are oxidized to carbon dioxide gas and water vapor. Nitrogen and excess oxygen are also present in the combustion products. The oxidation reaction generates heat, which is transferred and stored in the media. The hot media then radiates heat back to the incoming gas mixture and sustains the oxidation which takes place below the lower flammability limit. Above the reaction zone, the temperature of the media is at the operating temperature. The upward flowing gas emerges from the media and into the oxidizer head space, which is lined with refractory blanket. A 12" nozzle exhausts the reaction products into a refractory lined stack that vents to atmosphere.

The ES system is supplied with a single loop controller and analog indicators which provide the analog temperature control and indication. A PLC is provided for: alarm monitoring, control step sequencing, and discrete control.

-WARNING-

Process control safeguards, either software or hardware interlocks are carefully designed to permit safe operation of the oxidation system. Tampering with or defeating these safeguards may result in injury to personnel, property damage or interruptions of normal operation.

2.2 STARTUP OPERATOR INSTRUCTIONS

1. Align manual valves for operation.
2. Open instrument air valve H-901 and ensure appropriate air flow to each purged area.
3. Ensure all manual isolating valves on instruments are open.
4. Turn power on to control and power panels.
5. Place Dilution Air Blower B-230 in AUTO at the control panel PA-810.
6. Reset the ESD. Pull to Clear – Push to SHUTDOWN
7. Reset hardwired Interlocks by pressing the Interlocks Reset Button, HS-800, located on the front of the control panel (PA-810).
8. With all hardwired interlocks being cleared/reset, the system will perform a three minute Pre-purge of the system by automatically running the Dilution Air Blower, B-230.
9. Once the Pre-purge is complete, press the SYSTEM START button HS-800C located on the front of control panel PA-810. The system requires no further operator interaction.
10. The unit will automatically transition to PREHEAT mode and will operate in PREHEAT until TSSL-310D is satisfied.
11. At the end of PREHEAT, the fume block valve will open and the RUN light will indicate the unit is accepting fume.

2.3 EQUIPMENT OPERATING STATUS

MODE:	STARTUP	OPERATION	SHUTDOWN
STEP:	Preheat	Run	Shutdown
PURPOSE:	Preheat oxidizer to operating temperature	Process fume	Planned, unplanned or emergency shutdown
Dilution Air Blower B-230	Running when TSH-310B is active	Running	Running for 3 minute, then shut down
Oxidizer R-310	Preheating	Running	Purging, then Down
Stack S-540	Flow Thru	Flow Thru	Flow Thru

2.4 TYPICAL INSTRUMENT READINGS

MODE:	STARTUP	OPERATION	SHUTDOWN
STEP:	Preheat	Run	Shutdown
PURPOSE:	Preheat oxidizer to operating temperature	Process fume	Planned, unplanned or emergency shutdown
PI-210 Fume Header Pressure	0 "WC	0-30" wc @ Tie-Point	0 "WC
FI-210 Fume Flow	0 SCFM	0-2 SCFM	0 SCFM
PI-230 Dilution Air Pressure	53 "WC when blower is running	53" WC when blower is running	0"WC or 53"WC when blower is running
FI-230 Dilution Air Flow	92 SCFM when blower is running	92 SCFM when blower is running PDSL-230 SET POINT 92 SCFM	92 SCFM when blower is running
TI-230 Flame Arrestor Temperature	Ambient + 65°F	Ambient + 65°F TSHH-230 SP: 250°F	Ambient + 65°F
TI-310A Oxidizer Inlet Temperature	Ambient up to 150°F when blower is on	Ambient - 300° F	Ambient - 300° F
TI-310B Oxidizer Lower Bed Temperature	Ambient up to 150°F when blower is on	Ambient - 600° F	Ambient - 600° F
TI-310C Oxidizer Middle Bed Temperature	Ambient to 1700° F	1200°F to 1800°F	Ambient to 1800°F
TI-310D Oxidizer Outlet Temperature	Ambient to 2100°F	1400°F to 2100°F TSL-310D SP: 1400°F TSHH-310D SP: 2100°F	Ambient to 2100°F
TI-311A-C Heater Temperature	Ambient to 2100°F TSHH-311A-C SP: 2100°F	1200°F to 2100°F TSHH-311A-C SP: 2100°F	Ambient to 2100°F
PI-810 Instrument Air Pressure	55 psig to 100 psig PSLL-810 SP: 55 psig	55 psig to 100 psig PSLL-810 SP: 55 psig	0 psig to 100 psig PSLL-810 SP: 55 psig

3 OPERATING STEPS

-NOTICE-

Operating parameters contained in this manual are initial values that are subject to change during startup.

-NOTICE-

Before proceeding, operations personnel must have thoroughly read and be well trained in utilizing all sections of these instructions, vendor's literature and reference materials. Refer to vendor literature and operating manuals before starting or operating any equipment, instruments or control systems. Thermatrix offers no warranty, either express or implied, of system or equipment integrity or performance, if it is not operated in accordance with the instructions and specifications contained therein or within this document.

-WARNING-

No part of this system should be operated if any safety equipment, instruments, or control interlocks have been bypassed or defeated. It is the responsibility of the owner to maintain such equipment in proper working order, to follow the instructions in this document, and to exercise other normal and reasonable care in order to prevent injury to personnel, property damage, or interruptions of normal operation.

The ES-100 Thermal Oxidizer sequence has three operating steps as listed below.

- Preheat
- Run
- Shutdown

The following are Hardwired Shutdowns that will always trip the system to the Shutdown step. These shutdowns must be clear and reset prior to attempting to restart the system.

TAG NO.	DESCRIPTION
PSLL-810	Instrument Air Low-low Pressure
TSHH-310D	Oxidizer Outlet High-high Temperature
TSHH-310A	Oxidizer Inlet High-high Temperature
TSHH-311	Oxidizer Heater High-high Temperature
TSHH-280	Flame Arrestor High High
PDSL-230	Dilution Air Low Low Flow
UA-800C	Spare
HS-800A	Emergency Shutdown Button

The activities of each step are outlined in the following sections.

3.1 PREHEAT STEP

The purpose of *Preheat* step is to heat the oxidizer to operating temperature while monitoring the system to avoid excessive thermal gradients. Refer to Section 2.3 for equipment operational status, and Section 2.4 for typical instrument readings during this step.

3.1.1 Sequence Entry

Preheat step is entered from:

- *The Shutdown Step* when:
 - The System alarm(s) are acknowledged via HS-810 (Alarm Acknowledge), hardwired interlocks are reset by pushing HS-800 (Interlock Reset), and HS-800C (System Start) button is activated.
- *The Run Step* when:
 - The Oxidizer Outlet Temperature drops below 1400 °F, (TSSL-310D contact is open).

3.1.2 Control Step Permissives

The following permissives must be met in order to enter the *Preheat* step:

DEVICE	DESCRIPTION	SETPOINT
TSHH-310A	Oxidizer Inlet High High Temperature	< 300 °F Contact Closed
ZSC-210	Fume Block Valve	Contact Closed

3.1.3 Shutdown Interlocks

The following Shutdown interlocks are active in the *Preheat* step:

TAG NO.	DESCRIPTION
PSSL-810	Instrument Air Low-low Pressure
TSHH-310D	Oxidizer Outlet High-high Temperature
TSHH-310A	Oxidizer Inlet High-high Temperature
TSHH-311	Oxidizer Heater High-high Temperature
ZSC-210	Fume Block Valve Closed Position
TSHH-280	Flame Arrestor High High
PDSL-230	Dilution Air Low Low Flow
UA-800C	Auxiliary Trip #3
HS-800A	Emergency Shutdown Button

3.1.4 Alarms

The following alarms are active in the *Preheat* step:

TAG	DESCRIPTION
TAH-310B	Oxidizer Lower Bed High Temperature

3.1.5 Operator Actions

Preheat step is entered from:

- *Shutdown* step when:
 - The System alarm(s) are acknowledged via HS-810 (Alarm Acknowledge), hardwired interlocks are reset by pushing HS-800 (Interlock Reset), and HS-800C (System Start) button is activated.

3.1.6 PLC Actions

During *Preheat* step, the PLC will:

- Energize the Heater Contactor, JS-310,
- Turn on the Preheat Light, UL-800E, and
- When the Oxidizer Lower Bed Temperature is greater than 300 °F, (TSH-310B contact is open), energize B-230 and open XV-230. When the Oxidizer Lower Bed Temperature is less than 50 °F, (TSH-310B contact is closed), de-energize B-230 and close XV-230.

3.1.7 Sequence End Point Conditions

The *Preheat* sequence is complete when:

- Oxidizer Outlet Temperature is greater than 1400 °F, (TSSL-310D contact is closed).

3.1.8 Sequence Exit

Preheat step exits to:

- *Run* step if:
 - Oxidizer Outlet Temperature is greater than 1400 °F, (TSSL-310D contact is closed).
- *Shutdown* step if:
 - Any of the shutdown interlocks in Section 3.1.3 are tripped.

3.1.9 Automatic Block Valve and Power Contactor Status

In the *Preheat* step the automatic block valves will be positioned as shown below:

TAG NO.	DESCRIPTION	POSITION
MS-230	B230 Dilution Air Blower Motor Starter	ON / OFF
JS-310	Heater Contactor	ON
XV-230	Dilution Air Block Valve	OPEN / CLOSED
XV-210	Fume Block Valve	CLOSED

3.1.10 Controller and Control Valve Activities

In the *Preheat* step the controllers will be in the mode shown below:

TAG NO.	DESCRIPTION	MODE
TIC-310	Oxidizer Temperature Controller	AUTO/1700 F
TIC-311	Oxidizer Heater Temperature Controller	CASCADE/(SEE NOTE 1)
TZ-311A/B	Oxidizer Heater Power Controller	ACTIVE

Note 1: The controller set point is modulated by the output of TIC-310 and has an upper limit of 2100 °F (TY-310).

3.2 RUN STEP

The purpose of *Run* step is to process fume through the oxidation system. Refer to Section 2.3 for equipment operational status and Section 2.4 for typical instrument readings during this step.

3.2.1 Sequence Entry

Run step is entered from:

- *Preheat* step when:
 - Permissive TSLL-310D is satisfied, indicating the Oxidizer Outlet temperature is greater than 1400 °F. When the above permissives are satisfied, the “Run” lamp (UL-800G) will turn on, and the unit will sequence automatically to Run, and open Fume Block Valve, XV-210.

3.2.2 Control Step Permissives

The following permissives must be met in order to enter the *Run* step:

DEVICE	DESCRIPTION	SET POINT
TSLL-310D	Oxidizer Outlet Low-low Temperature	> 1400°F (Contact Closed)

3.2.3 Shutdown Interlocks

The following Shutdown interlocks are active in the *Run* step:

TAG NO.	DESCRIPTION
PSLL-810	Instrument Air Low-low Pressure
TSHH-310D	Oxidizer Outlet High-high Temperature
TSHH-310A	Oxidizer Bottom Bed High-high Temperature
TSHH-311	Oxidizer Heater High-high Temperature
TSHH-280	Flame Arrestor High High
PDSL-230	Dilution Air Low Low Flow
UA-800C	Spare
HS-800A	Emergency Shutdown Button

3.2.4 Alarms

The following alarms are active in the *Run* step:

TAG	DESCRIPTION
TAH-310B	Oxidizer Lower Bed High Temperature

3.2.5 Operator Actions

No operator actions are required in the *Run* step.

3.2.6 PLC Actions

During *Run* step, the PLC will:

- Open fume block valve XV-210,
- Turn off the Preheat Light, UL-800E, and turn on the Run Light, UL-800G, and
- When the Oxidizer Lower Bed Temperature is greater than 300 °F, (TSH-310B contact is open), energize B-230 and open XV-230. When the Oxidizer Lower Bed Temperature is less than 50 °F, (TSH-310B contact is closed), de-energize B-230 and close XV-230.

3.2.7 Sequence End Point Conditions

The *Run* sequence is a continuous step and subsequently does not have end point conditions.

3.2.8 Sequence Exit

Run step will exit to:

- *Preheat* step if:
 - Oxidizer Outlet Temperature is less than 1400 °F (TSL-310D contact is open).
- *Shutdown* step if:
 - any of the *Run* step shutdown interlocks trip (reference section 3.2.3).

3.2.9 Automatic Block Valve and Power Contactor Status

In the *Run* step the automatic block valves will be positioned as shown below:

TAG NO.	DESCRIPTION	POSITION
MS-230	B230 Dilution Air Blower Motor Starter	ON
JS-310	Heater Contactor	ON
XV-230	Dilution Air Block Valve	OPEN
XV-210	Fume Block Valve	OPEN

3.2.10 Controller and Control Valve Activities

In the *Run* step the controllers will be in the mode shown below:

TAG NO.	DESCRIPTION	MODE
TIC-310	Oxidizer Temperature Controller	AUTO/1600°F
TIC-311	Oxidizer Heater Temperature Controller	CASCADE/(SEE NOTE 1)
TZ-311A/B	Oxidizer Heater Power Controller	ACTIVE

Note 1: The controller set point is modulated by the output of TIC-310 and has an upper limit of 2100 °F (TY-310).

3.3 SHUTDOWN STEP

The purpose of *Shutdown* step is to shutdown the oxidizer in a controlled manner, to purge the system of flammables and to ensure that unsafe conditions neither persist nor develop. This step will be entered if maintenance is planned, or if operating, equipment, or instrument problems are encountered in other steps. Refer to Section 2.3 for equipment operational status and Section 2.4 for typical instrument readings.

3.3.1 Sequence Entry

Shutdown step is entered from:

- *Preheat or Run* step when:
 - the operator presses the Emergency Shutdown button HS-800A on the front of the control panel,
- *Preheat* step when:
 - any of the *Preheat* shutdown interlocks trip,
- *Run* step when:
 - any of the *Run* shutdown interlocks trip.

3.3.2 Control Step Permissives

There are no permissives required to enter the *Shutdown* step.

3.3.3 Shutdown Interlocks

There are no Shutdown interlocks active in the *Shutdown* step.

3.3.4 Alarms

There are no alarms active in the *Shutdown* step.

3.3.5 Operator Actions

Shutdown is an automatic sequence; therefore, no operator actions are required. Operator must clear the alarms by pushing Alarm Acknowledge Button, HS-810, then pushing the Interlock Reset button, HS-800, and finally pushing the System Start button, HS-800C, to restart the system.

3.3.6 PLC Actions

In *Shutdown* step, the PLC will:

- De-energize Heater Contactor, JS-310
- Close Fume Block Valve XV-210,
- Energize B-230 and open XV-230 for a 3 minute Post purge.

After the post-purge, the PLC will:

- Energize B-230 and open XV-230, when the Oxidizer Lower Bed Temperature is greater than 300 °F, (TSH-310B contact is open). When the Oxidizer Lower Bed Temperature is less than 50 °F, (TSH-310B contact is closed), de-energize B-230 and close XV-230.

3.3.7 Sequence End Point Conditions

The *Shutdown* sequence is a continuous step and subsequently does not have end point conditions.

3.3.8 Sequence Exit

Shutdown step will exit to:

- *Preheat* step if the post-purge is complete and operator presses the System Start button, HS-800C & TE-310D < 1400 °F
- *Run* step if the post-purge is complete and operator presses the System Start button, HS-800C & TE-310D > 1400 °F

3.3.9 Automatic Block Valve and Power Contactor Status

In the *Shutdown* step the automatic block valves will be positioned as shown below:

TAG NO.	DESCRIPTION	POSITION
MS-230	B230 Dilution Air Blower Motor Starter	ON / OFF
JS-310	Heater Contactor	OFF
XV-230	Dilution Air Block Valve	OPEN / CLOSED
XV-210	Fume Block Valve	CLOSED

3.3.10 Controller and Control Valve Activities

In the *Shutdown* step the controllers will be in the mode shown below:

TAG NO.	DESCRIPTION	MODE
TIC-310	Oxidizer Temperature Controller	N/A
TIC-311	Oxidizer Heater Temperature Controller	N/A
TZ-311A/B	Oxidizer Heater Power Controller	N/A

4 REFERENCE INFORMATION

4.1 Instrument Index

TAG NO.	DESCRIPTION	SERVICE	MANUFACTURER
HS-230	Blower on/auto switch	Dilution Air	
PI-230	Pressure indicator	Dilution Air	Ashcroft
FI-230	Flow indicator	Dilution Air	King Instrument
XV-230	On/off block valve	Dilution Air	Marwin
XV-210	On/off block valve	Fume	Marwin
FI-210	Flow indicator	Fume	King Instrument
PI-210	Pressure indicator	Fume	Ashcroft
PI-810	Pressure indicator	Instrument Air	Ashcroft
PSLL-810	Pressure switch	Instrument Air	Ashcroft
PICV-810	Z-purge	Instrument Air	Bebco
PICV-820	Z-purge	Instrument Air	Bebco
PICV-830	Z-purge	Instrument Air	Bebco
TE-311	Temperature element	Oxidizer	C-Temp
TE-310A	Temperature element	Oxidizer	C-Temp
TE-310B	Temperature element	Oxidizer	C-Temp
TE-310C	Temperature element	Oxidizer	C-Temp
TE-310D	Temperature element	Oxidizer	C-Temp
TSHH-310A	Temperature switch	PA-810	Watlow
TSH-310B	Temperature switch	PA-810	Watlow
TIC-310	Temperature indicating controller	PA-810	Watlow
TIC-311	Temperature indicating controller	PA-810	Watlow
TSSL-310D	Temperature switch	PA-810	Watlow
TSHH-310D	Temperature switch	PA-810	Watlow
TZ-310A	Solid state relay	PA-820	Watlow
TZ-310B	Solid state relay	PA-820	Watlow
JS-310	Contactactor	PA-820	Siemens
PDSL-230	Low Differential pressure switch	Dilution air	Dwyer

4.2 Equipment Index

TAG NO.	DESCRIPTION	SERVICE	MANUFACTURER
B-230	Blower	Dilution Air	Rotron
F-230	Filter	Dilution Air	Rotron
PT-310	Protection Tubes	Oxidizer	TMX Fabricator
HE-310	Heating Elements	Oxidizer	I2R
M-310	Ceramic Media	Oxidizer	Petroware
R-310	Oxidizer	Fume	TMX Fabricator
S-540	Stack	Fume	TMX Fabricator
PA-810	Control Panel	Electric	Hoffman
PA-820	Power Panel	Electric	Hoffman
SX-310	Sparger	Fume	TMX Fabricator
FA-280	Flame arrestor	Total flow	Protego

4.3 Line Index

LINE SIZE- NUMBER	FROM	TO	MATERIAL OF CONSTRUCTION
2"-DA2301	F-230	P2101	Carbon Steel, Schedule 40
1/2"-P2101	TP-1	FA-280	Carbon Steel, Schedule 40
2"-DA2301-Q	FA-280	R-310	Carbon Steel, Schedule 40
3/8"-IA9101	TP-3	Cabinets and valves	SS Tubing

4.4 System Outline Drawing

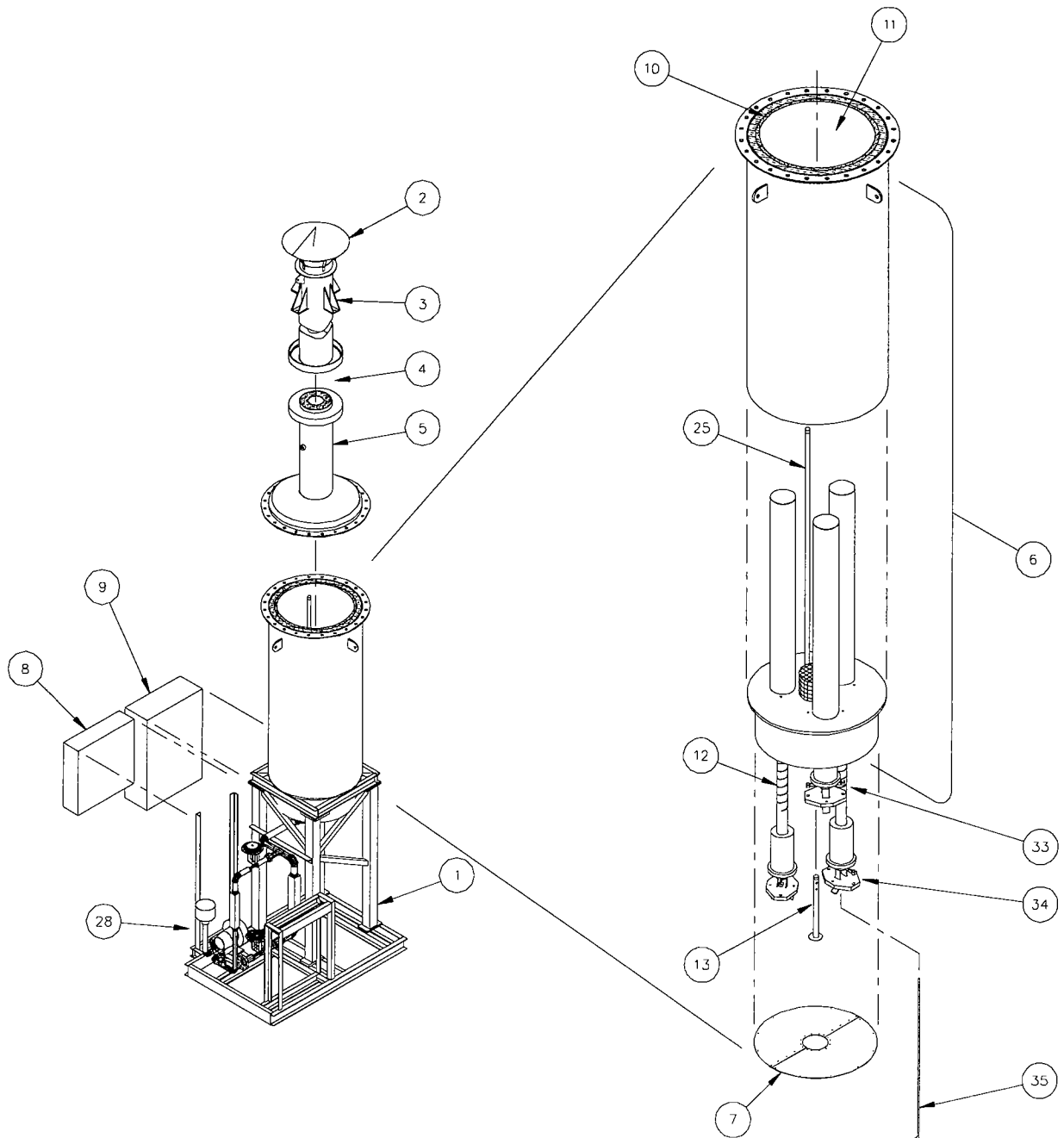

Item no.	Description	Tag no.
1.	Skid Assy	ES100-S52-01
2.	Stack Cap weldment	TE4172-M33-05-09
3.	Upper Stack Assy	TE4172-M33-05
4.	Stack Expansion Joint	TE4172-M72-01-11
5.	Lower Stack Assy	TE4172-M33-05
6.	Oxidizer Assy	ES100-M33-01
7.	Bottom Plates	ES100-M33-01-24/25
8.	Control Panel	PA-810, ES100-E41-01
9.	Power Panel	PA-820, ES100-E41-04
10.	Refractory	ES100-M33-04
11.	Media	ES100-M33-04
12.	Heater Assy	ES100-M33-07-01
	12a. Heater thermowell	
	12b. Ceramic standoffs	
	12c. Mounting clamps	
	12d. Electrical connectors	
13.	Sparger Assy	TE4172-M81-02
14.	Instrument manifold	TE4172-M81-02
15.	Fume Flow Indicator	FI-210
16.	Air Flow Indicator	FI-230
17.	Oxidizer type Z purge	PCV-830
18.	Dilution air low flow switch	PDSL-230
19.	Total Flow Pressure Indicator	PI-210
20.	Air Pressure Indicator	PI-230
21.	Instrument air pressure Indicator	PI-810
22.	Instrument air pressure switch	PSLL-810
23.	Deflagration arrestor temperature element	TE/TW-280
24.	Oxidizer temperature element	TE-310A/B/C/D
25.	TE Thermowells	TW-310
26.	Fume block valve	XV/ZSC-210
27.	Air block valve	XV-230
28.	Dilution air blower	B-230
29.	Deflagration Arrestor	FA-280
30.	Silencer	F-230
31.	1/2" Dia. Fiber rope gasket, fiber frax or equal	
32.	High-temp. RTV sealant	
33.	Clamp weldment	ES100-M33-08-06/07
34.	Fiberboard Spacers	ES100-M33-08-05
35.	Heater Temperature Element	TE-311

5 INSTALLATION DETAIL

The following instructions detail the unpacking, assembly and utility connections for the Thermatrix, ES-100 Flameless Thermal Oxidizer (FTO).

Note: Task #2 includes a description for heater installation. This description, is applicable to reinstallation of heaters after replacement since the the heaters are shipped installed in the oxidizer vessel.

Note: To avoid unnecessary breakage or problems, please read the heater installation instructions completely before installing. Installing the heaters is most easily accomplished with two people.

The ES-100 FTO unit is shipped in the following pieces on one truck:

1. Oxidizer shipped upright with packing and heaters installed. Lower stack attached.
2. Upper stack with rain cap.
3. Support skid with blower, valving, rotameters and control panels
4. Misc parts in a box

Task One: Estimated Time: 4-8 hours

A large fork truck, cherry picker, or crane will be required to remove the oxidizer shell, support skid and stack from the truck. A six-foot or longer spreader will be very helpful and flexible straps or cables are required. The support skid weighs approximately 1500 lbs., the oxidizer weighs approximately 1000 lbs., and the stack weighs approximately 300 lbs.

1. Place the ES-100 support skid on the foundation. Anchor bolts should be existing or added shortly after the support skid is placed on the foundation. See anchor bolt layout drawing for detail. (Drawing No. TE4172-S32-01)
2. Remove the lower stack from the top of the oxidizer and inspect the ceramic media. Media should be level, not broken, and at the appropriate height. The top layer of ceramic media should be within 12 inches below the top flange of the oxidizer. If the level of media is a few inches lower than the allowable limits, add additional media to the desired level.
3. Place the Oxidizer onto the 4" tube steel legs. The oxidizer must not be tilted or dropped as the media inside may shift or break. Rotate the oxidizer in relationship to the skid to align the electrical conduit connections. Bolt the oxidizer to the skid. (Eight bolts)
4. Inspect the bottom flange of the stack for attached debris, clean as necessary.
5. Install an high temperature fiberglass rope gasket on the top oxidizer flange. Place the rope gasket on the inside of the flange bolt holes.
6. Lift the stack and bolt to the oxidizer.

At this point all heavy lifting is complete.

Task Two: Estimated Time: 4-8 hours using two trained personnel. (Heater installation description included here is for replacement of elements. Original elements are shipped installed)

Install heaters and misc. parts to oxidizer skid. Although these instructions are complete and accurate, it is recommend that Thermatrix personnel assist with heater installation during the initial installation.

1. Remove the bottom sheet metal covers from the bottom of the oxidizer. A nut driver or socket and drill motor will be helpful.
2. Remove ceramic heaters from Box No. 1. The lead in sleeves, end spacers, and support plates are in box No. 3.
3. Assemble the heater. Refer to picture No. A for identification of the heater component parts.
4. Lay the heater down horizontally. Wrap fiberglass cloth around the heater just below the molded collar. Attach the two piece stainless heater support over the fiberglass cloth. Tighten snugly. Remove the hitch pins. Save pins for later installation. (See pictures No. B and C for the details)
5. Utilizing two people, hold the heater vertically and carefully slide the thin doughnut shaped ring down the heater and allow it to rest on the molded heater collar. (See picture No. D) Be careful to protect the ceramic thermowell extending out the bottom of the heater.
6. Next slide the ceramic centering spacer over the heater and allow it rest on the doughnut ring. (See picture E)
7. Place the top centering cap on the top of the heater. (See picture F)
8. Adjust the ½" nuts and washers on the ½" all-thread to support the heater assembly. When properly installed, one nut/washer will be above the stainless support and one nut/washer will be below the support.
9. Slowly and carefully, insert the heater assembly up into the heater protection tube. (See picture G) Do not place the heater all the way up into the protection tube at this time. Allow a 2 inch gap between the ceramic collar and the bottom of the oxidizer. Allow the stainless support to rest on the lower washer and ½" nut. Install the two hitch pins onto the stainless support. These pins will ensure that the heater will not fall during the remainder of the installation process and operation mode.
10. Take care when tightening to prevent breaking the ceramic ring. When in place, adjust and tighten the ½" nuts against the stainless support from the top and bottom.
11. Notice that the heater positions are numbered on the bottom of the oxidizer when installing the ceramic fiberboard electrical spacer/thermocouple supports. Install the correct numbered parts to the correct positions.

